

# The 1999 Tahoe Police Package Owner's Manual Supplement

---

## **1-1 Seats and Restraint Systems**

This section tells you how to use your seats and safety belts properly.

## **2-1 Features and Controls**

This section explains how to start and operate your vehicle.

## **4-1 Your Driving and the Road**

Here you'll find helpful information and tips about the road and how to drive under different conditions.

## **5-1 Problems on the Road**

This section tells you what to do if you have a problem while driving.

## **6-1 Service and Appearance Care**

Here the manual tells you how to keep your vehicle running properly and looking good.

## **10-1 Special Equipment Options Standard with Tahoe Police Package**

This section explains special equipment options that are standard with your vehicle.

## **11-1 Special Equipment Options Available with Tahoe Police Package**

This section explains special equipment options that are available for your vehicle.

## **12-1 Index**

Here's an alphabetical listing of almost every subject in this manual. You can use it to quickly find something you want to read.

This supplement contains information that pertains to the operation of your vehicle. The first five sections of this supplement correspond to the sections in your Owner's Manual. The next two sections contain information on special equipment that is available with the Tahoe Police Package. This supplement, along with your Owner's Manual, will assist you in the proper use and maintenance of your vehicle.

Please keep this supplement with the Owner's Manual in your vehicle, so it will be there if you ever need it while you're on the road. If you sell your vehicle, leave the Owner's Manual Supplement and the Owner's Manual with the vehicle.

This manual includes the latest information at the time it was printed. We reserve the right to make changes in the product after that time without notice.

© Copyright 1997 General Motors Corporation. All Rights Reserved. General Motors, GM, CHEVROLET and the corresponding emblem TAHOE are registered trademarks of General Motors Corporation.

Part No. 15018010 A First Edition

## Section 1 Seats and Restraint Systems

---

### Lap Belt Cinch Feature

Your vehicle has a lap belt cinch feature for the right front passenger. Some vehicles may also have this feature for the driver.

You can tell if the driver's safety belt has this feature by first pulling the lap part of the belt out all the way. Then, let it go back into the retractor, just a few inches. If the belt locks when you try to pull it out again, that's the lap belt cinch feature working normally. However, if you can pull the belt out after letting it go back a few inches, then the driver's safety belt doesn't have this feature.

If you have the cinch feature and you don't want the lap belt to move freely, pull the belt out all of the way to set the lock. To permit the lap belt to move freely again, unbuckle the belt, let it retract all the way, and buckle up again.



## Section 2 Features and Controls

---

### Keys

#### Specific Cylinder Unit for Single Key System -- SEO 6A5, 6E2 or 6E8

If your vehicle is equipped with one of these options, the entire fleet of vehicle locks can be key coded the same.

#### Alternate Key Codes Available

- Standard Production-Random Code
- SEO 6A5-Specific Fleet Key Code
- SEO 6E2-Specific Fleet Key Code
- SEO 6E8-Specific Fleet Key Code

For specific key code information, contact your dealer.

### Door Locks

#### Inactive Rear Door Locks -- SEO 6N6

Your vehicle may be equipped with door locks that have been deactivated. Only the driver's power door lock switch locks or unlocks the latches of the rear doors. A lock rod and retainer have not been installed on the rear doors. To reactivate the lock and unlock function of the rear doors, obtain one left side lock rod GM Part No. 15973843, one right side lock rod GM Part No. 15973844 and two guides GM Part No. 15592648 from your dealer. Refer to the service manual for the proper installation procedure.

## Running Your Engine While You're Parked

Turn off the following factory equipment if emergency lighting and communication equipment are operating, while you are parked with the engine idling for an extended period:

- Air Conditioner
- Fan
- Rear Window Defogger
- Factory Audio System

For additional information, refer to the Owner's Manual.

## Lamps

### Daytime Running Lamps

Daytime Running Lamps (DRL) can make it easier for others to see the front of your vehicle during the day. DRL can be helpful in many different driving conditions, but they can be especially helpful in the short periods after dawn and before sunset.

The DRL system will make your headlamps come on at a reduced brightness when:

- the ignition is on,
- the DRL OFF switch is deactivated (United States only),
- the headlamp switch is off and
- the parking brake is released.

When the DRL system is on, only your headlamps and the DRL indicator light will be on. The taillamps, sidemarker and other lamps won't be on. Your instrument panel won't be lit up either.

When it begins to get dark, your DRL indicator light is a reminder to turn your headlamp switch on. The other lamps that come on with your headlamps will also come on.

When you turn off the headlamp switch, the regular lamps will go off, and your headlamps will change to the reduced brightness of DRL.

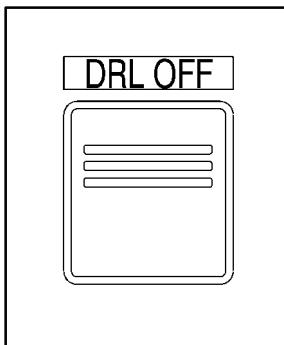

### **United States only**

Your vehicle (United States only) may be equipped with a switch that will turn the DRL and the DRL indicator off.

The radio display will also go off whenever the DRL system is turned off with the switch.

The brake system warning light will remain on if the parking brake is applied, even with the DRL system off. The safety belt reminder light will also remain on or flash for about 70 seconds if the driver's belt is unlatched.

Press the top of the DRL OFF switch to turn off the DRL and the DRL indicator.

Press the bottom of the DRL OFF switch to turn the DRL on.

As with any vehicle, you should turn on the regular headlamp system when you need it.

## Instrument Panel Cluster

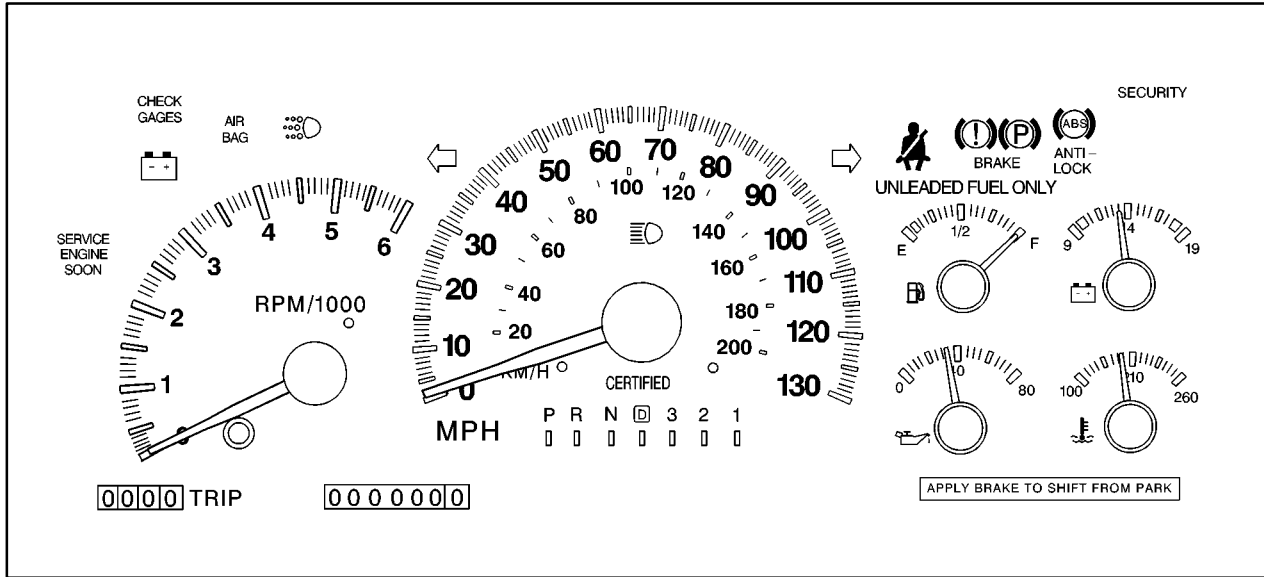

**United States version shown, Canada similar**

Your instrument cluster is designed to let you know at a glance how your vehicle is running. You'll know how fast you're going, about how much fuel you have and many other things you'll need to know to drive safely and economically.



## Speedometer and Odometer

Your certified speedometer lets you see your speed in both miles per hour (mph) and kilometers per hour (km/h). Your odometer shows how far your vehicle has been driven, in either miles (used in the United States) or kilometers (used in Canada).

### Tamper-Resistant Odometer

Your odometer is tamper-resistant. The odometer will show silver lines between the numbers if someone tries to turn it back.

You may wonder what happens if your vehicle needs a new odometer installed. If the new odometer can be set to the mileage total of the old odometer, then it must be. But if it can't, then it's set at zero, and a label must be put on the driver's door to show the old mileage reading when the new odometer was installed.

### Trip Odometer

The trip odometer can tell you how far your vehicle has been driven since you last set the trip odometer to zero.

To reset the trip odometer, fully press the reset button located near the trip odometer readout. If the reset button is not fully pressed, the trip odometer may not go all the way back to zero. If it doesn't, you may have to press the reset button again to reset the readout to zero.

## Tachometer

Your tachometer displays the engine speed in revolutions per minute (rpm).

## Warning Lights, Gages and Indicators

### Check Gages Light

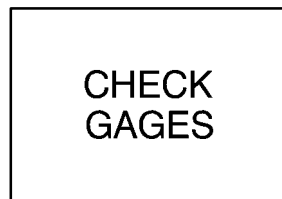

If this warning light comes on and stays on, check your oil pressure gage to see if it is in the warning zone.

If it is, have your vehicle serviced right away.



# NOTES

---

---

---

---

---

---

---

---

---

---

---

---

---

---

---

---

---

---

---

---

---

---

---

---

---

---

## Section 4 Your Driving and the Road

---

### Towing a Trailer

The police package vehicle is not intended to tow a trailer.



# NOTES

---

---

---

---

---

---

---

---

---

---

---

---

---

---

---

---

---

---

---

---

---

---

---

---

## Section 5 Problems on the Road

### Changing a Flat Tire

#### Lock-Spare Tire, Keyed Two-Piece Hoist Shaft -- SEO 8A0 (If Equipped)

Your vehicle may be equipped with a keyed, two-piece spare tire hoist shaft. This shaft provides security protection in two ways. One is a special key feature on the extension shaft. The second feature is that the lock shaft spins freely, preventing the hoist from operating without the key shaft.

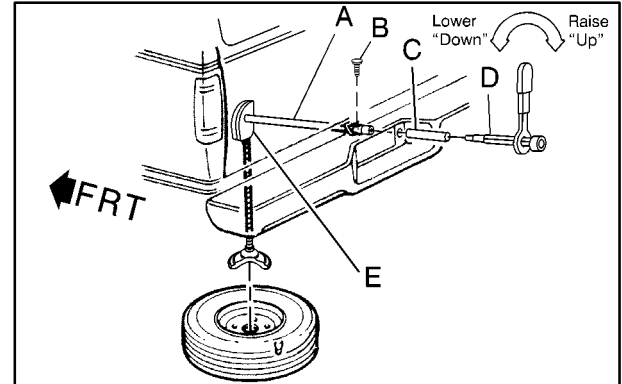

- A. Extension Shaft
- B. Pin
- C. Key Shaft
- D. Wheel Wrench
- E. Spare Tire Hoist

When you take delivery of your new vehicle, be sure to remove the key shaft (C) from the extension shaft (A). This is done by removing the pin (B) that holds the two pieces together. The pin is located midway on the shafts behind the bumper.

To remove the key shaft:

1. Lower the spare tire to get better access to the pin.
2. Remove the pin.
3. Raise the spare tire.
4. Remove the key shaft by pulling it through the hole in the rear bumper.

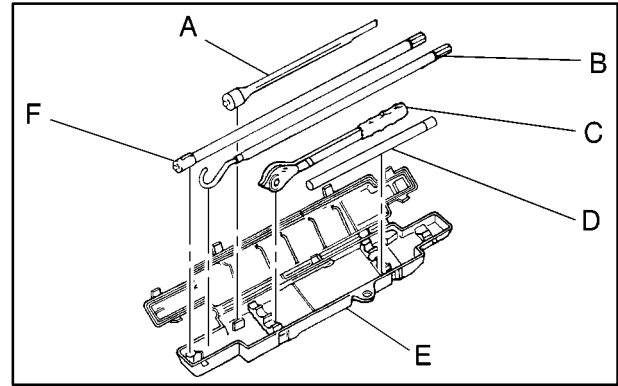

- A. Wheel Wrench
- B. Jack Handle
- C. Ratchet
- D. Key Shaft
- E. Jack Tool Storage Box
- F. Jack Handle Extension

Store the key shaft in the jack tool box or a similar secure location. The key shaft must be used to lower the spare tire. Plan to use the key shaft in case of a flat tire or for tire rotation. The key shaft works with the standard tire wrench.

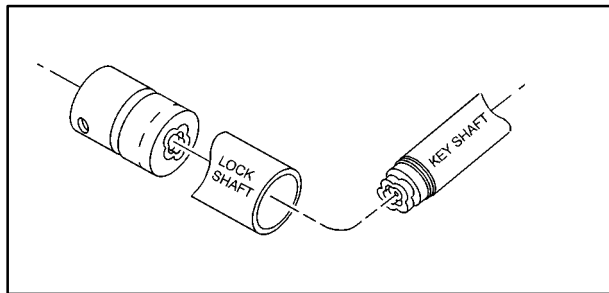

Note the special rippled circle shape on the inserted end of the key shaft. This is the key feature. It mates with the same shaped recess inside the lock shaft on the spare tire hoist. There are many key shapes so there is a low probability that another shaft will have the same shape.

Important: register your key code with the manufacturer by completing and mailing the card in the information packet. Keep the key code stub with your vehicle documents. In case the key shaft is lost, you can contact the manufacturer for a replacement. The *correct* keyed shaft *must* be used to access the spare tire.





## Section 6 Service and Appearance Care

---

### Brakes

Many of the components of the brake system used on the Tahoe Police Package are unique to this vehicle. Before doing any service work, consult the appropriate service manual.

Refer to your Owner's Manual for additional information on the brake system. See "Brakes" in the Index of the Owner's Manual.

### Brake Adjustment

The rear drum brake adjustment activates, as needed, during firm brake apply in forward stops. Before doing any service work, consult the appropriate service manual.

### Dual Battery System -- SEO 8Y9 (If Equipped)

Your vehicle may be equipped with a dual battery system. The two batteries are connected so that both supply battery power to the vehicle at the same time (they are connected in parallel).

Refer to your Owner's Manual for additional information on the batteries. See "Battery" in the Index of the Owner's Manual.



## Section 10 Special Equipment Options Standard with Tahoe Police Package

---

### **NOTICE:**

Before modifying or adding any wiring, be sure that it will work properly with your vehicle's wiring system. Because there are many modifications that can be made for many different bodies and accessories, GM cannot take responsibility for any changes made.

- Have work done by an experienced electrical technician.
- All wiring must be properly protected by fuses, etc. and must be routed properly so that it won't be cut, pinched or rubbed by other parts of the vehicle.

**NOTICE: (Continued)**

### **NOTICE: (Continued)**

- Don't route wiring in areas where it will get very hot.
- Be sure not to overload the vehicle's wiring, connectors and components.
- All added wire must be at least the same size as the wire it's being attached to for proper fuse protection.

### **NOTICE:**

Care must be taken during customer installation of equipment and wiring to ensure that all holes drilled in the body are properly sealed and that the vehicle wiring harnesses, piping and other components have not been displaced or damaged.

## Wiring Provisions for 12-Volt Power Supply

Battery power and ground circuits are provided through 60 amp fuses to a relay and fuse panel located in the center of the instrument panel below the audio system and climate controls. Two main battery and ignition controlled circuits, each fused at 30 amps, are provided through the 5 ft (1.52 m) leads coiled at the front passenger's side footwell. Ground leads for each circuit are also fused at 30 amps.

## Electrical Connections

### Installation Instructions -- 12-Volt Power Supply

1. Disconnect the negative (-) battery cable at the battery. The negative (-) cable must be disconnected before the positive wiring lead is connected to the power accessory.
2. Locate the power supply harness under the instrument panel near the center of the vehicle. The wire bundle consists of the ignition (IGN), battery (BAT) and negative (NEG) wire feeds.
3. Remove the tape to release the wire bundles from the power supply harness.
4. Remove the protective tape from the ends of the wires that are to be used to connect the power accessory. Do not remove the tape from any unused wires. Tape unused wires back in their original position under the instrument panel.
5. The upfitter is to complete the wiring installation with additional wire required for the specific electrical accessory power connection. The wire color and gauge, 12-gauge (3.0 mm), is to be the same as the wiring of the installed harness.

**NOTICE:**

**If you do not turn off electrical accessories such as the windshield wiper switch or the radio, they could be damaged. Turn off all electrical accessories before attaching cables to the battery.**

6. The ignition must be turned off and the vehicle must be vacated prior to attaching the cables to the battery.
7. Connect the negative (-) battery cable to the battery. Tighten the bolt to 11 lb-ft (15 N·m).
8. Set the clock time, radio pushbuttons and Theft-Deterrent feature as needed. See “Audio Systems” in the Owner’s Manual.

The IGN A and IGN B connections have voltage supplied, with the ignition turned to ACCESSORY or RUN.

The BAT A and BAT B connections have voltage supplied at all times.

**NOTICE:**

**Don’t overload the vehicle’s wiring, connectors and components. Overloading the vehicle’s electrical system can damage the vehicle.**

The combined electrical load of IGN A and BAT A must not exceed 21 amps (250 watts). Additionally, the combined electrical load of IGN B and BAT B must not exceed 21 amps (250 watts). The combined electrical load of all circuits must not exceed 42 amps (500 watts).

## Servicing Relays and Fuses

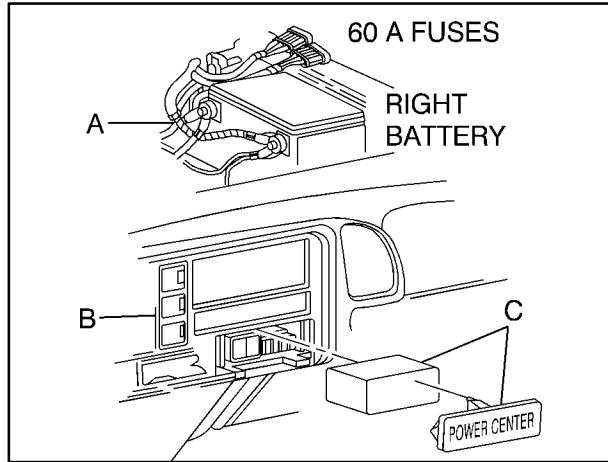

- A. Engine Compartment
- B. Instrument Panel
- C. Fuse and Relay Covers

The following information tells you how to access your vehicle's relay and fuse center for checking and replacing fuses.

To access the instrument panel relay and fuse center, first remove the fuse panel cover. Lift the cover from the left side, using the relief slot, and remove the cover.

The interior fuse and relay center is located in the center of the instrument panel below the audio system and climate controls. Use a screwdriver to remove the center cover by lightly expanding the spring clips on each side of the cover. Use a fuse puller if your vehicle has one. Replace a relay with a GM Part No. 12088592 relay, or equivalent.

After servicing the panel, install the relay and fuse center cover by pressing the cover back on. Make sure the larger slot in the cover faces the driver's side. Install the fascia cover of the instrument panel relay and fuse center on the instrument panel. Make sure the relief slot is on the driver's side of the instrument panel.

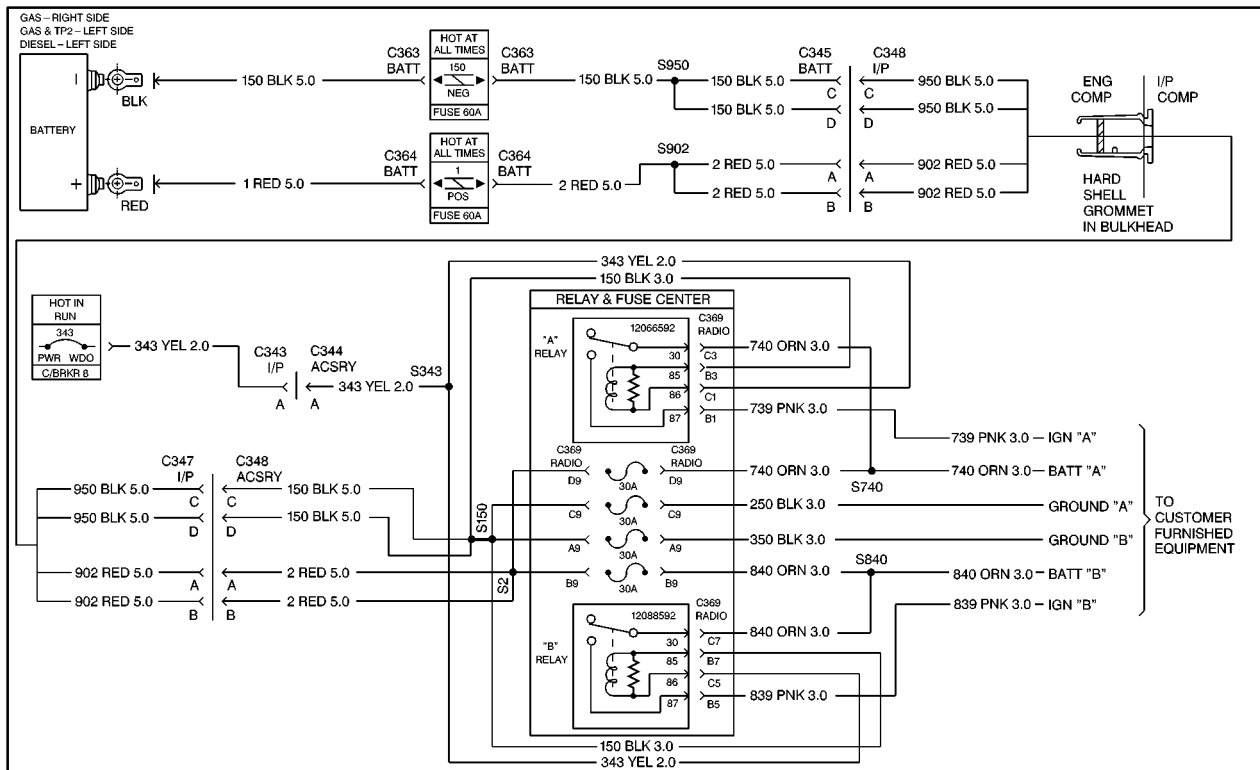

Wiring Diagram for 12-Volt Power Supply

## Wiring Provisions for Roof Mounted Accessories

Battery power is supplied through a 30 amp fuse to a connector located in the roof bow approximately 32 inches (81 cm) rearward of the windshield centerline. Power is controlled with a switch located in the instrument panel to the left of the steering wheel column. The external wiring and sealing grommet are shipped loose in the glove box compartment. A hole must be drilled in the vehicle's roof to install the wiring to the roof lighting assembly.

## Electrical Connections

### Installation Instructions -- Emergency Vehicle Roof Panel Lamp

1. Disconnect the negative (-) battery cable at the battery.
2. Drill a 1.25 inch (31.8 mm) diameter hole in the outer roof panel. The drilled hole should pierce the outer roof panel only. Refer to the previous illustration for the proper hole location.

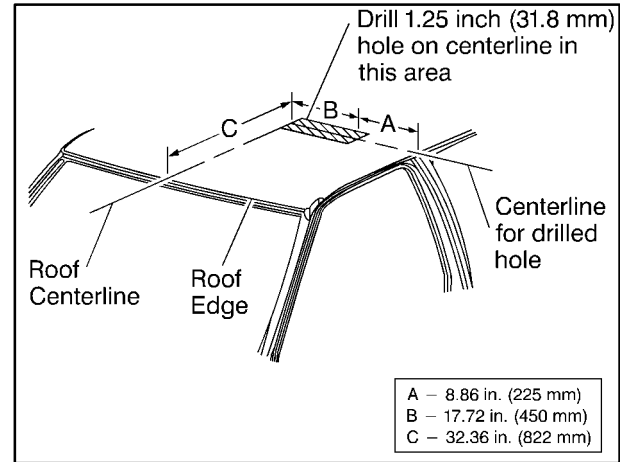



**NOTICE:**

**Use care when pulling the harness through the panel hole to avoid wire insulation damage. Sharp edges around the drilled hole can damage the vehicle's wiring. Be sure to remove all sharp edges from the drilled hole in the roof panel.**

3. Pull the vehicle installed lamp harness wires (covered with gray tape) through the outer roof panel hole.
4. Cut the installed lamp harness wires to the length required for the hole location used on your vehicle.
5. Strip the wire ends, add terminals (GM Part No. 12052827), and push the terminals into the connector (GM Part No. 12064750).
6. Install the orange wire in cavity "A" and the black wire into cavity "B."
7. Push in the secondary lock (GM Part No. 12064751) at the wire entrance side of the connector.
8. Attach the harness assembly (GM Part No. 12150251) to the roof emergency lamp.

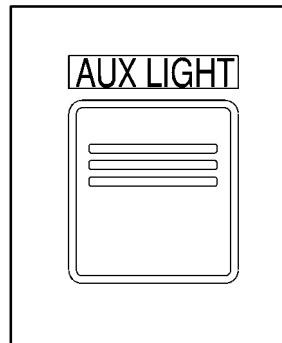

9. With the AUX LIGHT switch off, complete the connection with the main emergency roof panel lamp wiring harness and the extension wiring harness.

10. Cover the mated connectors with supplied foam. Push the foam covered connectors and excess wire through the roof panel hole into the roof channel.

**NOTICE:**

**If you do not turn off electrical accessories such as the windshield wiper switch or the radio, they could be damaged. Turn off all electrical accessories before attaching cables to the battery.**

11. The ignition must be turned off and the vehicle must be vacated prior to attaching the cables to the battery.
12. Connect the negative (-) battery cable to the battery and tighten the bolt to 11 lb-ft (15 N·m). Set the clock time, radio pushbuttons and the Theft-Deterrent feature as needed. See “Audio Systems” in the Owner’s Manual.
13. Move the emergency roof panel lamp switch to ON, to test the roof lamp. After ensuring that the lamp is working properly, install the grommet-part of the emergency roof panel wiring harness into the drilled hole securely. Seal with silicone sealer to prevent water leakage.

## NOTICE:

**Don’t overload the vehicle’s wiring, connectors and components. Overloading the vehicle’s electrical system can damage the vehicle.**

The maximum rated load of the light bar power supply is 21 amps. Your equipment requirements must not exceed 21 amps (250 watts).

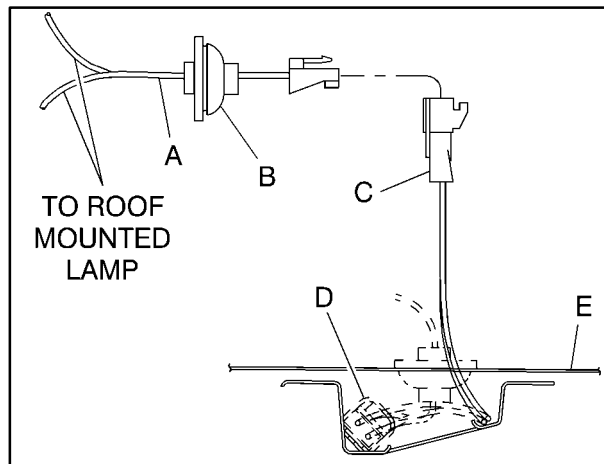

### Roof Mounted Accessory Wiring

- A. Harness Assembly (GM Part No. 12150251)
- B. Grommet (Roof)
- C. Harness Connector, Secondary Lock and Terminal (GM Part No. 12064750, GM Part No. 12064751 and GM Part No. 12052827)
- D. Foam Insulator (Adhesive-Backed)
- E. Vehicle Outer Roof Panel

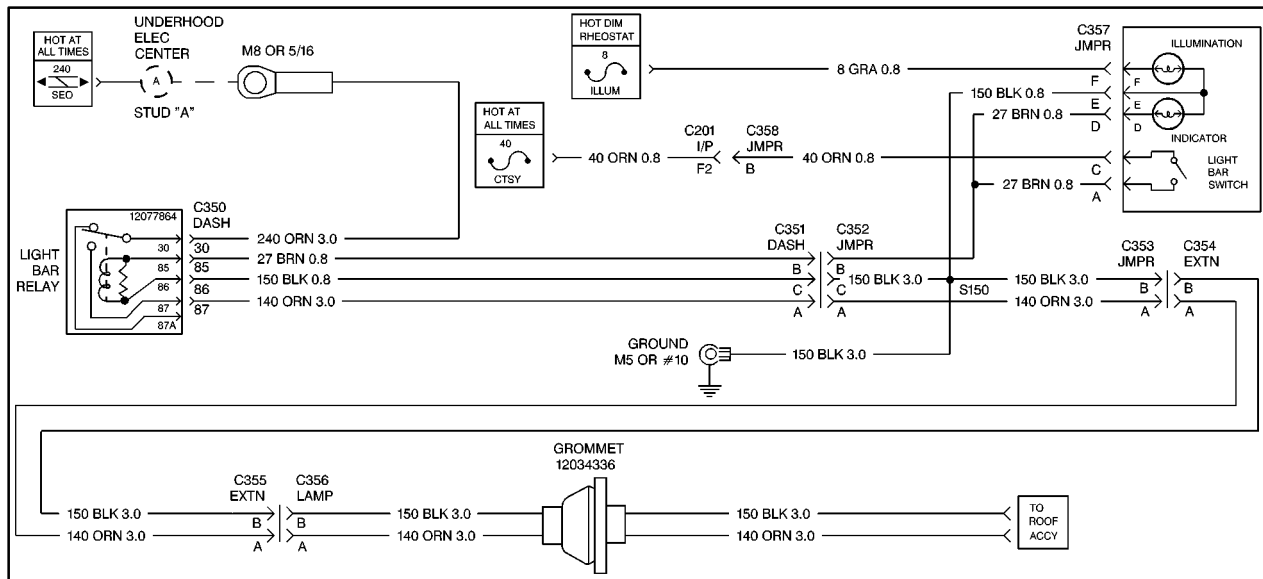

**Wiring Diagram for Roof-Mounted Accessories**

## Wiring Provisions for Vehicle Grille Lamps and Speaker

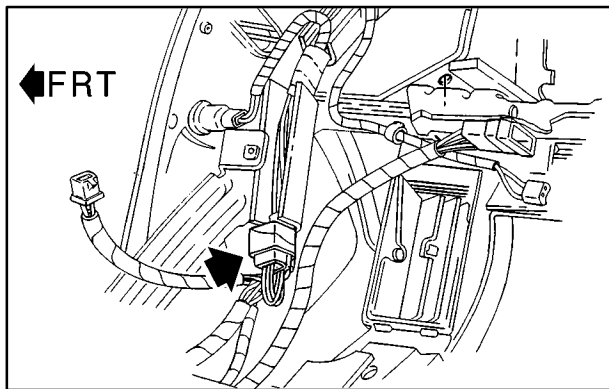

**Alternating Signal Flasher**

One 16-gauge wire is connected to the alternating signal flasher that is mounted under the instrument panel. There is 5 ft (1.52 m) of extra wire mounted under the instrument panel. Two 16-gauge wires are connected to the flasher and are contained in the forward lamp harness behind the grille. Two 16-gauge speaker lead wires are routed from under the instrument panel to an area behind the grille. All four wires have 12 inches (30.5 cm) of extra wire left in a coil behind the grille. Grille lamps and a speaker are not included. A 16-gauge

control wire for use with a customer furnished headlamp flasher system is routed from the right front of the radiator to a coil under the instrument panel.

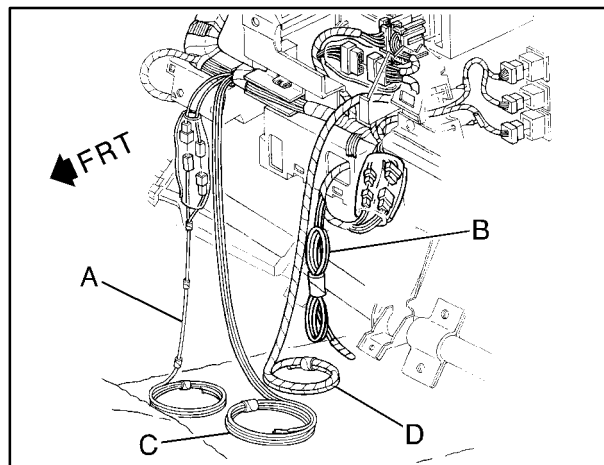

**Center of Instrument Panel -- Wiring Harnesses**

- A. Horn - SEO 6J4
- B. Auxiliary Power - Fused Center or SEO 6J1
- C. Vehicle Grille Lamps and Speaker Wiring
- D. Front Radio Speaker Jumper - SEO WX7

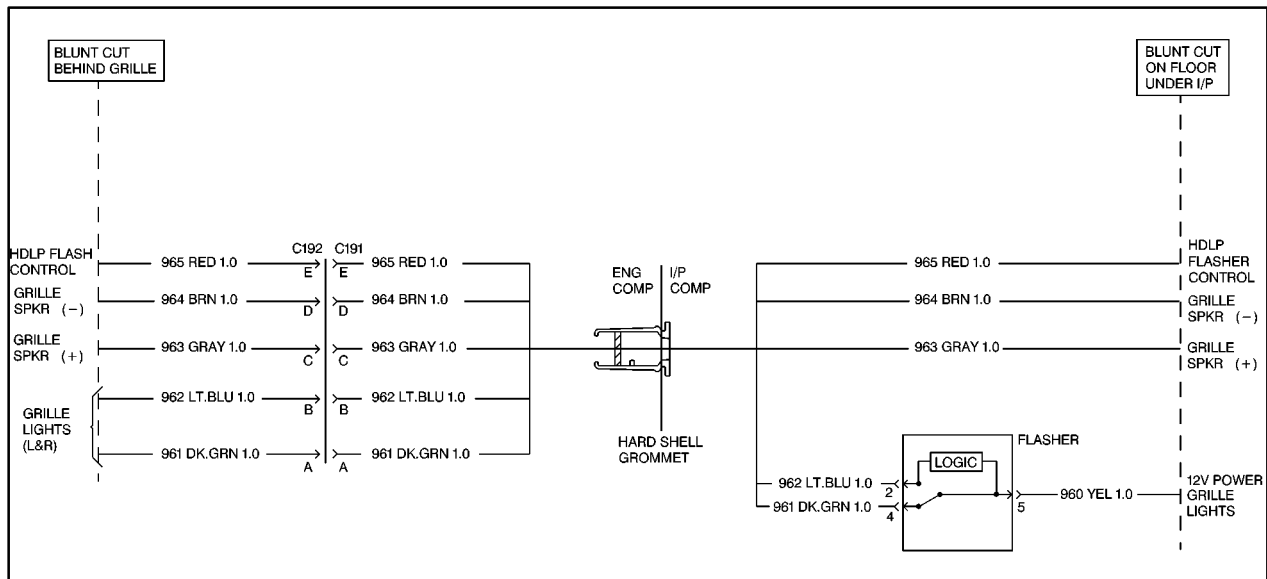

**Wiring Diagram for Vehicle Grille Lamps and Speaker Wiring Provisions**

## Auxiliary Battery Power

A covered fuse block is provided as a part of the battery system and is mounted on the radiator shroud inboard from the passenger-side battery.

## Electrical Connections

### NOTICE:

**Don't overload the vehicle's wiring, connectors and components. Overloading the vehicle's electrical system can damage the vehicle.**

The maximum recommended current draw at the mega fuse block connection point is 125 amps. All added wiring must be the appropriate size (gauge) and have the proper fuse protection to handle this current rating. The wiring from the mega fuse connection to the first accessory fuse must be capable of carrying 140 percent of the mega fuse rated value of 175 amps. All wiring downstream of the first accessory fuse must be sized to carry 140 percent of the accessory fuse rating.

You can get electrical components from your authorized GM dealer. Many Packard electrical components are also available from Pioneer Standard Company (1-800-PACKARD). Pioneer Standard may also be able to supply customer wiring studs and jumpers made to your specifications.

## Owner-Added Accessory Connectors

Use the following electrical connection point for any customer furnished equipment or accessories. Make your accessory (positive +) connection at the primary terminal on the mega fuse block. Also, when connecting an owner-added accessory (positive +) terminal to the power accessory stud, be sure that the stud nut is fully threaded onto the power accessory stud and tighten to 9 to 13 lb-ft (12 to 18 N·m). Make sure all connections are tight.

## Primary Electrical Supply Connection at the Mega Fuse Block

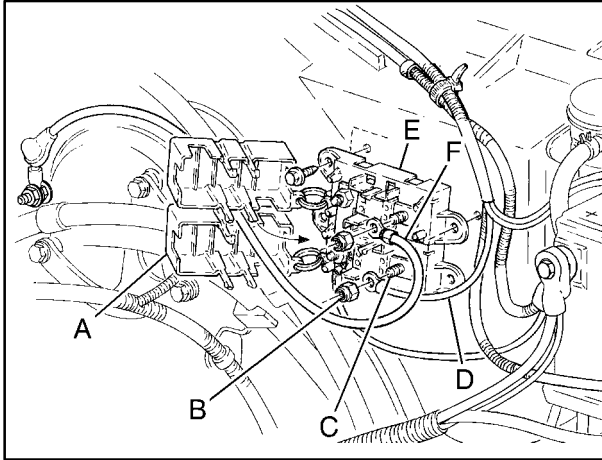

**Rear of Radiator Support**

- A. Cover
- B. Nut
- C. Terminal for Owner-Added Accessory
- D. Power Feed for Instrument Panel Auxiliary Power Supply
- E. Mega Fuse Block (Dual 175 amp fuses)
- F. Generator Lead

To connect the customer furnished equipment at the mega fuse block, use the following steps:

1. Disconnect the negative (-) battery cable at the battery.
2. Remove the mega fuse block cover. The mega fuse block is located on the passenger side front of the engine compartment and is mounted on the rearward side of the upper fan shroud.

### **NOTICE:**

**Don't overload the vehicle's wiring, connectors and components. Overloading the vehicle's electrical system can damage the vehicle.**

3. Remove the terminal nut from the lower outboard terminal of the mega fuse holder. Put the positive (+) terminal ring of the accessory on the mega fuse terminal stud. Wiring must be sized correctly. The maximum load is 125 amps on this terminal.
4. Replace the lock washer and terminal nut. Tighten the terminal nut to 9 to 13 lb-ft (12 to 18 N·m). Replace the mega fuse block cover. The threads of the terminal nut must be fully engaged on the stud.
5. Attach appropriately sized ground cable from accessory to any grounding location on the engine block or frame.



**NOTICE:**

**If you do not turn off electrical accessories such as the windshield wiper switch or the radio, they could be damaged. Turn off all electrical accessories before attaching cables to the battery.**

6. The ignition must be turned off and the vehicle must be vacated prior to attaching the cables to the battery.
7. Connect the negative (-) battery cable and tighten to 11 lb-ft (15 N·m). Set the clock, radio pushbuttons and the Theft-Deterrent feature as needed. See “Audio Systems” in the Owner’s Manual.

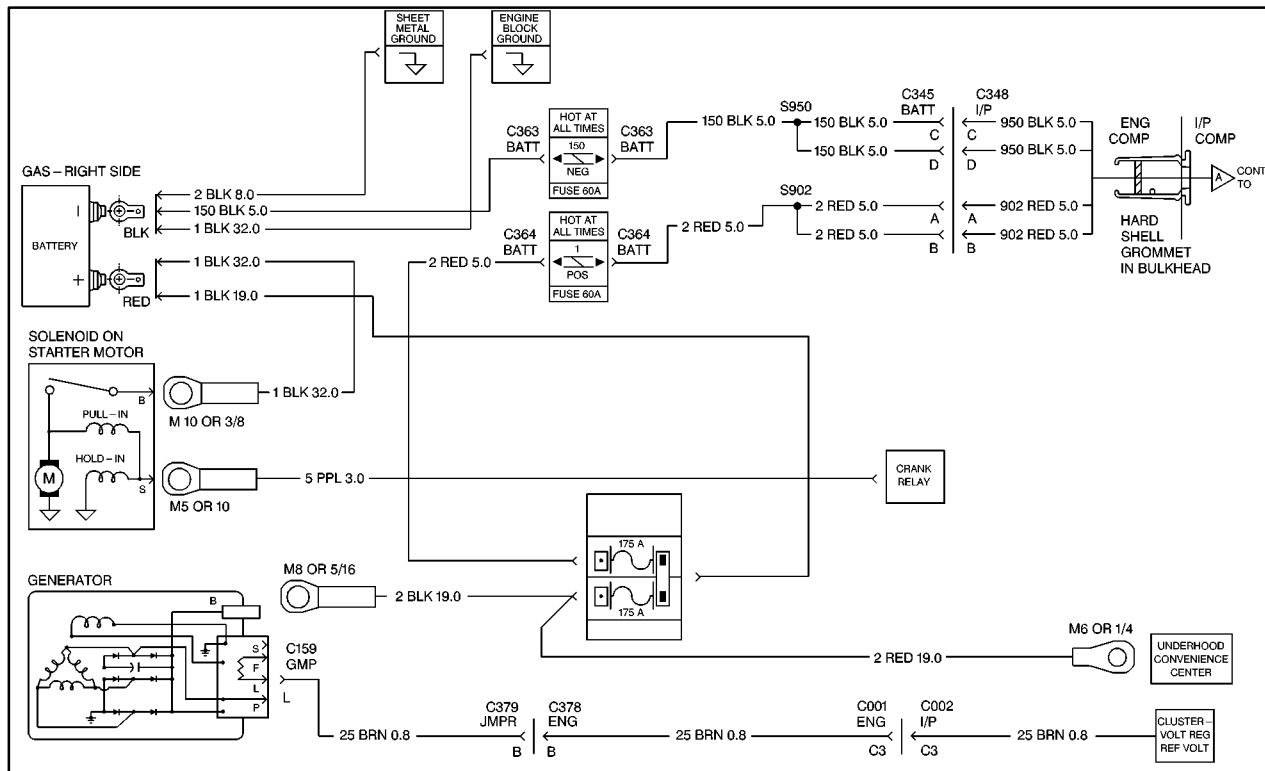

**Wiring Diagram for Auxiliary Battery Power**

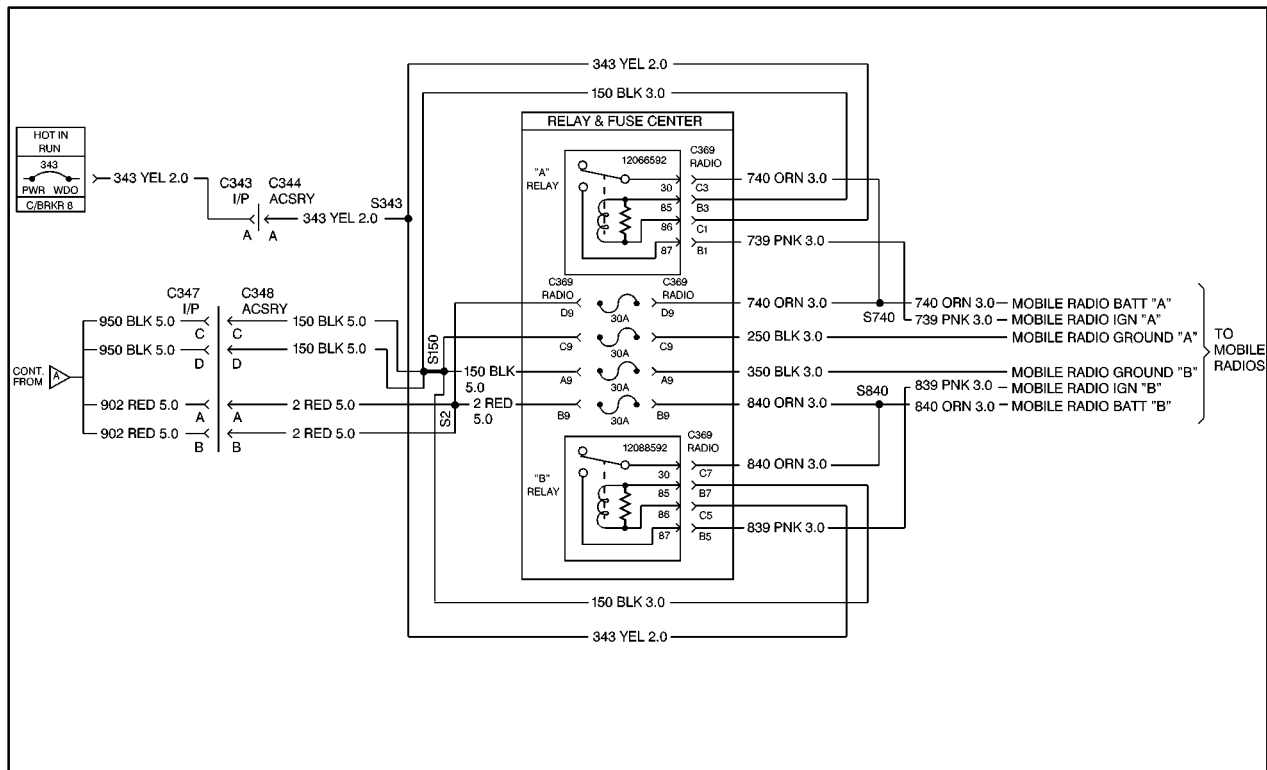

Continued Wiring Diagram for Auxiliary Battery Power



## Section 11 Special Equipment Options Available with Tahoe Police Package

---

### **NOTICE:**

Before modifying or adding any wiring, be sure that it will work properly with your vehicle's wiring system. Because there are many modifications that can be made for many different bodies and accessories, GM cannot take responsibility for any changes made.

- Have work done by an experienced electrical technician.
- All wiring must be properly protected by fuses, etc. and must be routed properly so that it won't be cut, pinched or rubbed by other parts of the vehicle.

**NOTICE: (Continued)**

### **NOTICE: (Continued)**

- Don't route wiring in areas where it will get very hot.
- Be sure not to overload the vehicle's wiring, connectors and components.
- All added wire must be at least the same size as the wire it's being attached to for proper fuse protection.

### **NOTICE:**

Care must be taken during customer installation of equipment and wiring to ensure that all holes drilled in the body are properly sealed and that the vehicle wiring harnesses, piping and other components have not been displaced or damaged.

## Auxiliary Dome Lamp -- SEO 6C7

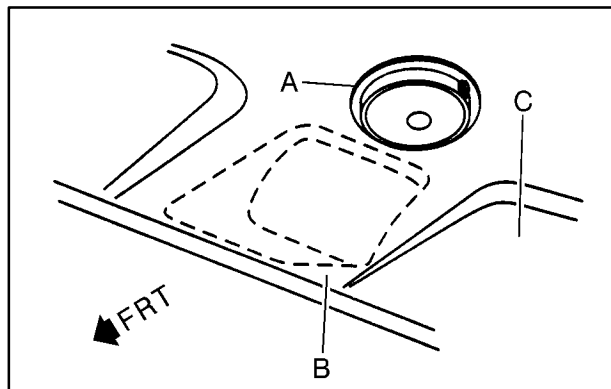

- A. Auxiliary Dome Lamp
- B. Optional Rear A/C Controls
- C. Sun Visor

The auxiliary dome lamp is located on the headliner rearward of the windshield and between the driver and the front passenger. The switch for the dome lamp is located at the rear of the base of the lamp. The lamp is wired independently. To operate the lamp, press the switch. To turn the lamp off, press the switch again.

## Wiring Provisions for 12-Volt Power Supply -- SEO 6J1

SEO 6J1 replaces the fused wiring provisions for the 12-volt power supply with a circuit breaker system.

Battery power and ground circuits are provided through 60 amp fuses to a relay and circuit breaker panel located in the center of the instrument panel below the audio system and climate controls. One 25 amp circuit breaker provides power directly from the battery. One 25 amp and one 15 amp circuit breaker provide power through the contacts of the control relays. Each relay can be operated by a 16-gauge control lead included in the 5 feet (1.52 m) coil under the instrument panel. These control leads can be connected through customer furnished switching. A 16-gauge ignition controlled power lead is included in the 5 feet (1.52 m) coil. A system ground lead is also provided.

## Electrical Connections

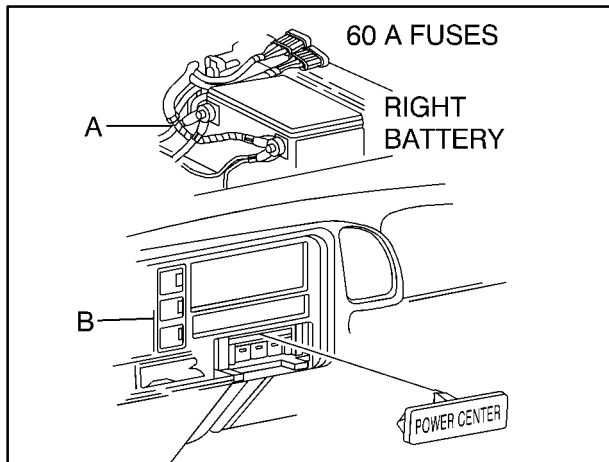

A. Engine Compartment

B. Instrument Panel

## Installation Instructions -- 12-Volt Accessory Power Supply

1. Disconnect the negative (-) battery cable at the battery. The negative (-) cable must be disconnected before the positive wiring lead is connected to the power accessory.
2. Locate the power supply harness under the instrument panel near the center of the vehicle. The wire bundle consists of the ignition (IGN), battery (BAT) and negative (NEG) wire feeds. See "Vehicle Grille Lamps and Speaker" in the Index for an illustration that shows the wiring harness location in the center of the instrument panel.
3. Remove the tape to release the wire bundles from the power supply harness.

4. Remove the protective tape from the wires that are to be used to connect the customer accessory. Do not remove the tape from unused wires. Tape unused wires back in their original position under the instrument panel.
5. The upfitter is to complete the wiring installation with additional wire required for the specific electrical accessory power connection. The wire color and gauge, 12 gauge (3.0 mm), is to be the same as the wiring of the installed harness.
7. Connect the negative (-) battery cable to the battery. Tighten the bolt to 11 lb-ft (15 N·m).
8. Set the clock time, radio pushbuttons and the Theft-Deterrent feature as needed. See “Audio Systems” in the Owner’s Manual.

The customer central IGN “R1” and “R2” require customer switched voltage to activate the “A” or “B” relays.

The customer BAT “A” connection has circuit breaker protected voltage supplied at all times.

**NOTICE:**

**If you do not turn off electrical accessories such as the windshield wiper switch or the radio, they could be damaged. Turn off all electrical accessories before attaching cables to the battery.**

**NOTICE:**

**Don’t overload the vehicle’s wiring, connectors and components. Overloading the vehicle’s electrical system can damage the vehicle.**

6. The ignition must be turned off and the vehicle vacated prior to attaching the cables to the battery.



The combined electrical load of customer “R1,” “R2” and customer BAT “A” must not exceed 44 amps (525 watts). The electrical load for customer furnished equipment must not exceed the following:

- Customer “R1” -- 10 amps
- Customer “R2” -- 17 amps
- BAT “A” -- 17 amps

### **Servicing Relays and Circuit Breakers**

The following information tells you how to access your vehicle’s relay and circuit breaker center for checking and replacing components.

The circuit breaker and relay panel is located in the center of the instrument panel, below the audio system and the climate controls. Replace the relay with GM Part No. 12513368 relay, or equivalent. Replace the 15 amp circuit breaker with GM Part No. 1237660 circuit breaker, or equivalent. Replace the 25 amp circuit breaker with GM Part No. 12376661 circuit breaker, or equivalent.

After servicing the panel, install the circuit breaker and relay panel cover by pressing the cover back on. Make sure the larger slot in the cover faces the driver’s side. Install the cover of the instrument panel relay and fuse center on the instrument panel. Make sure the relief slot is on the driver’s side of the instrument panel.

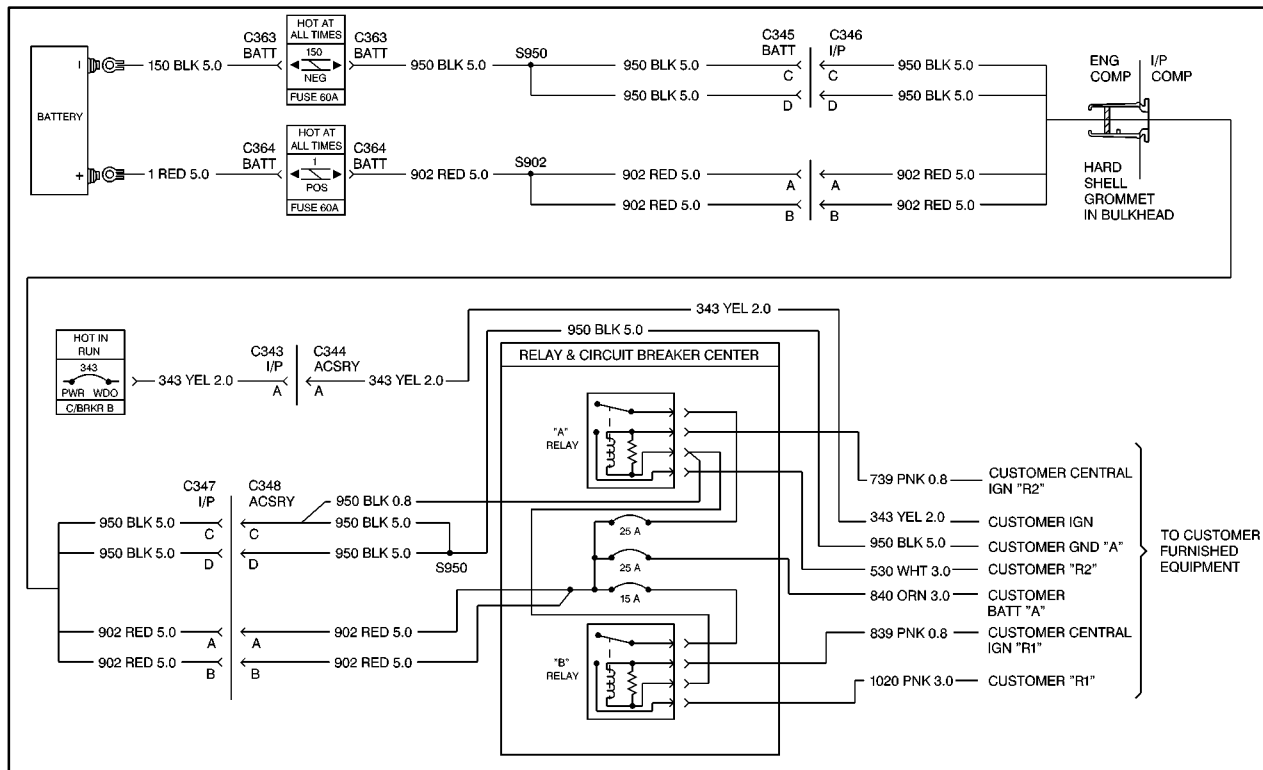

Wiring Diagram for SEO 6J1

## Spotlamp -- SEO 7X6

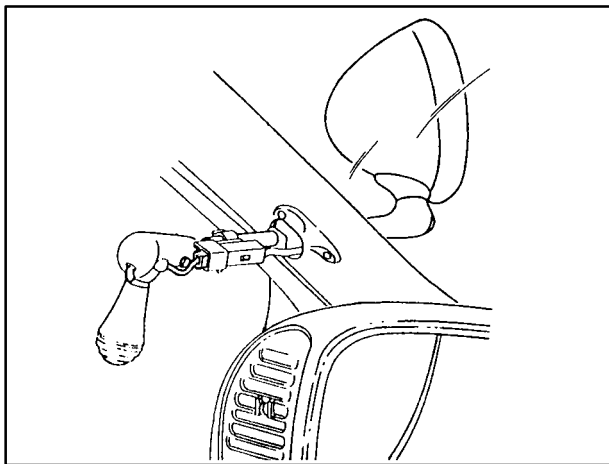

This option includes one Unity Model 225/S6 six-inch 160,000 candlepower (50 watt) pillar-mounted left-hand halogen spotlamp. The spotlamp is fused by the 20 amp AUX POWER fuse located in the instrument panel fuse block.

For spotlamp bulb replacement procedures, see the appropriate section of the service manual.

## Spotlamps -- SEO 7X7

SEO 7X7 includes a left-hand and a right-hand spotlamp.

## Spotlamp Provisions -- SEO 7X8

Installation of Spotlamp Provision -- SEO 7X8 is similar to SEO 7X9, except that it includes only a left-hand spotlamp provision.

## Spotlamp Provision -- SEO 7X9

This option includes provisions for the installation of a left-hand and a right-hand pillar-mounted spotlamp. The provision includes a hole in the pillar for spotlamp shaft routing, mounting bracket, shaft, door clearance notch, cover and a power connector. The spotlamp wiring is fused by the 20 amp AUX POWER fuse located in the instrument panel fuse block.

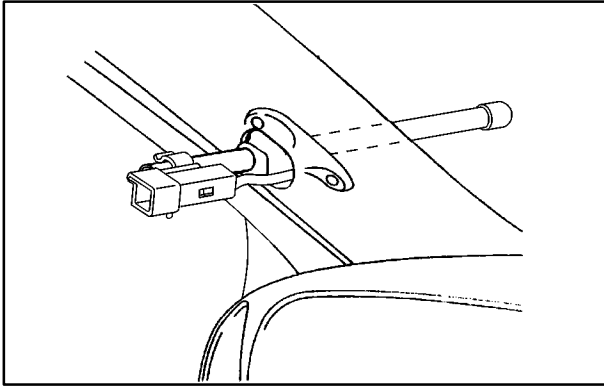

## Spotlamp Installation

### Installation Instructions

1. Disconnect the negative (-) battery cable at the battery.
2. Attach the spotlamp. Refer to the manufacturer's installation instructions for the spotlamp installation procedures.

3. Locate the spotlamp wiring harness.
4. Attach the spotlamp wiring harness connector to the spotlamp.
5. Snap the spotlamp connector to the spotlamp shaft.

### **NOTICE:**

**If you do not turn off electrical accessories such as the windshield wiper switch or the radio, they could be damaged. Turn off all electrical accessories before attaching cables to the battery.**

6. The ignition must be turned off and the vehicle must be vacated prior to attaching the cables to the battery.
7. Connect the negative (-) battery cable to the battery. Tighten the bolt to 11 lb-ft (15 N·m). Set the clock time, radio pushbuttons and the Theft-Deterrent feature as needed. See "Audio Systems" in the Owner's Manual.

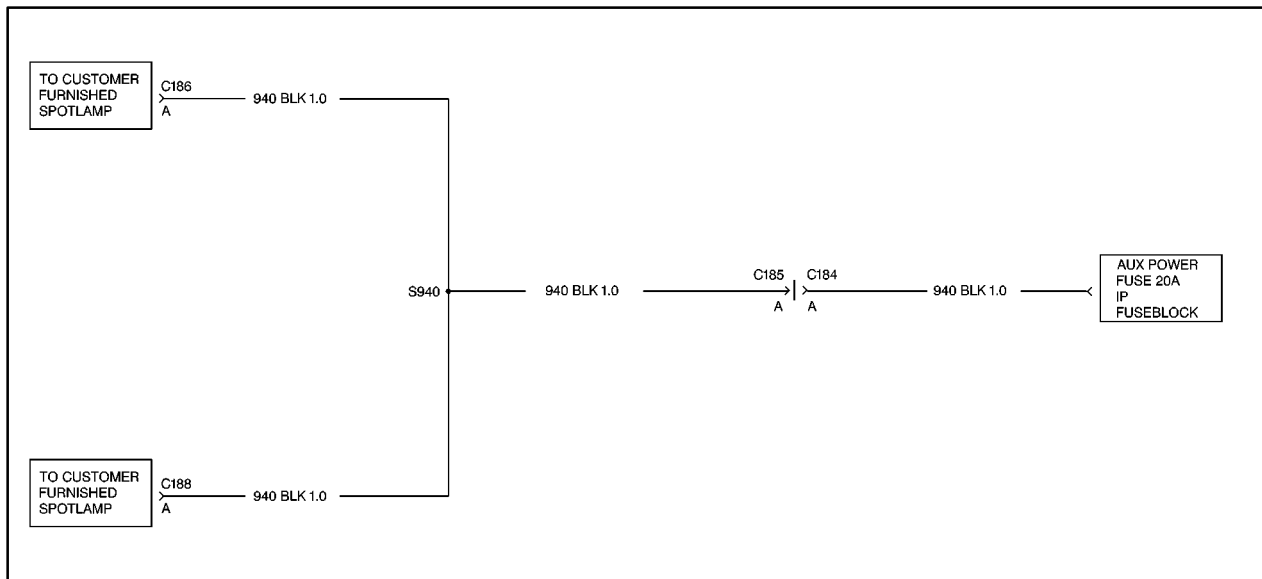

**Wiring Diagram for Spotlamp(s) Provision**

## **Wiring Provisions for Horn/Siren Circuit -- SEO 6J4**

This provision permits customer connection of a switch to select either horn or siren operation by the horn button.

Two 16-gauge wires are connected to an in-line connector in the horn circuit of the instrument panel harness under the instrument panel. The end of this harness extension is in a 5 feet (1.52 m) coil of wire under the instrument panel.

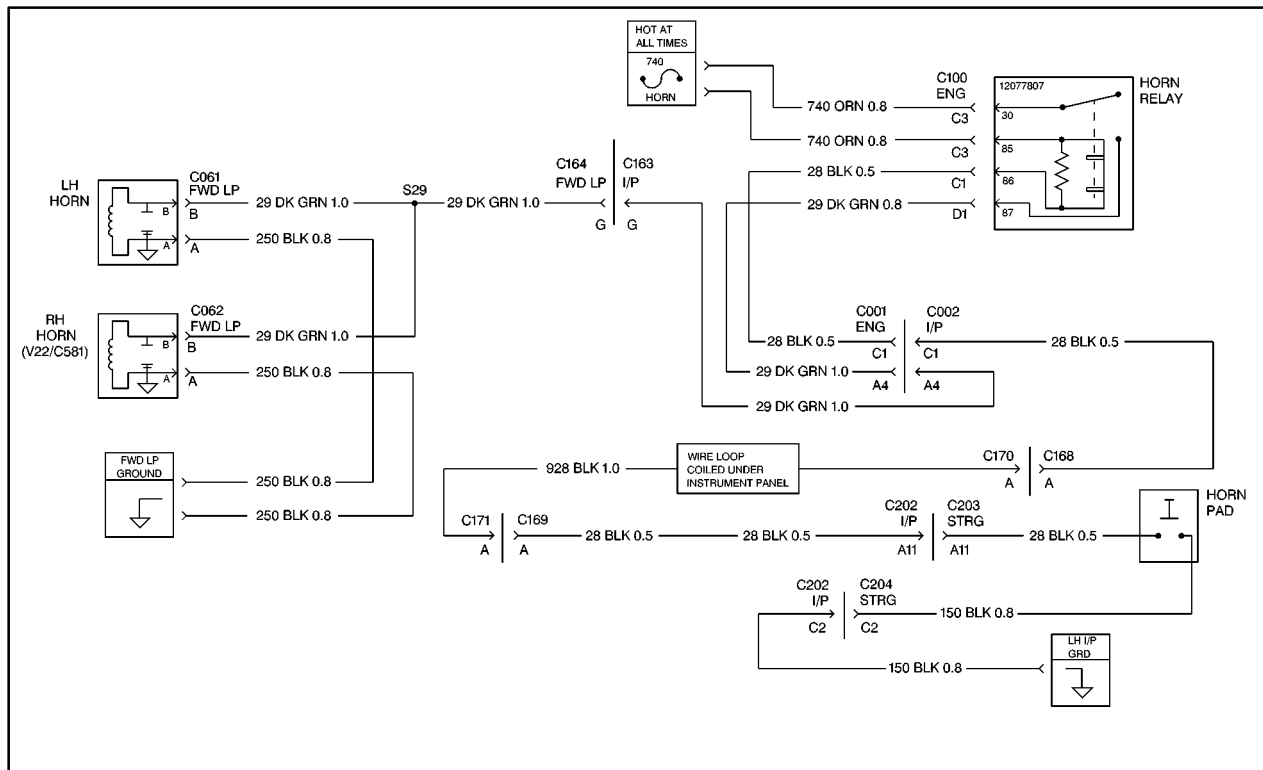

Wiring Diagram for SEO 6J4

## Wiring Provisions for Roof-Mounted Accessories -- SEO 6F5

There are eight 12-gauge wires (including one ground wire) and two 10-gauge wires that are color coded and mounted in a vehicle with this option. This is a universal roof wiring harness for roof-mounted equipment. There are 3 feet (0.9 m) of extra wire that is coiled under the instrument panel and approximately 2 feet (0.6 m) are located in the roof bow approximately 32 inches (82 cm) rearward of the windshield centerline. The customer must drill the roof hole and provide the proper sealing grommet.

### Electrical Connections

#### Installation Instructions

1. Disconnect the negative (-) battery cable at the battery.
2. Drill a hole in the outer roof panel in the location shown. The drilled hole should pierce the outer roof panel only. Refer to the illustration above for the proper hole location. The hole size is determined by the customer supplied grommet.

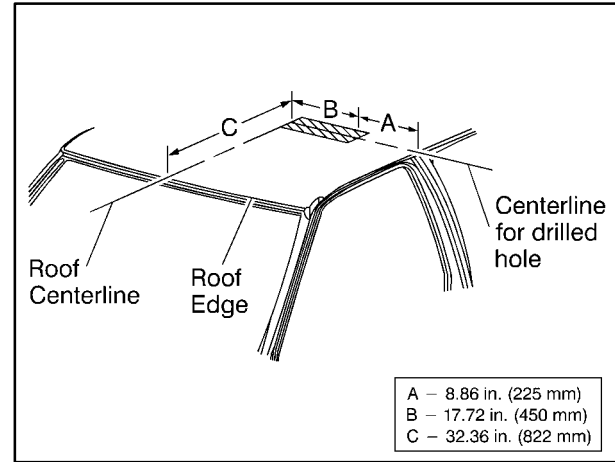



**NOTICE:**

**Sharp edges around the drilled hole can damage the vehicle's wiring. So be sure to remove all sharp edges from the drilled hole in the roof panel.**

3. Pull the vehicle harness wires (covered with gray tape) through the outer roof panel hole. Use care when pulling the harness through the panel hole to avoid wire insulation damage.
4. Cut the harness wires to the length required for the hole location used on your vehicle. Strip the wire ends and add appropriate terminals.
5. Attach the harness assembly to the roof-mounted accessory.

**NOTICE:**

**If you do not turn off electrical accessories such as the windshield wiper switch or the radio, they could be damaged. Turn off all electrical accessories before attaching cables to the battery.**

6. The ignition must be turned off and the vehicle must be vacated prior to attaching the cables to the battery.
7. Connect the negative (-) battery cable to the battery and tighten the bolt to 11 lb-ft (15 N·m). Set the clock time, radio pushbuttons and the Theft-Deterrent feature as needed. See “Audio Systems” in the Owner’s Manual.
8. Install a customer provided roof panel grommet where the roof panel wiring harness passes through the hole previously drilled in the roof. Seal with silicone sealer to prevent water leakage.

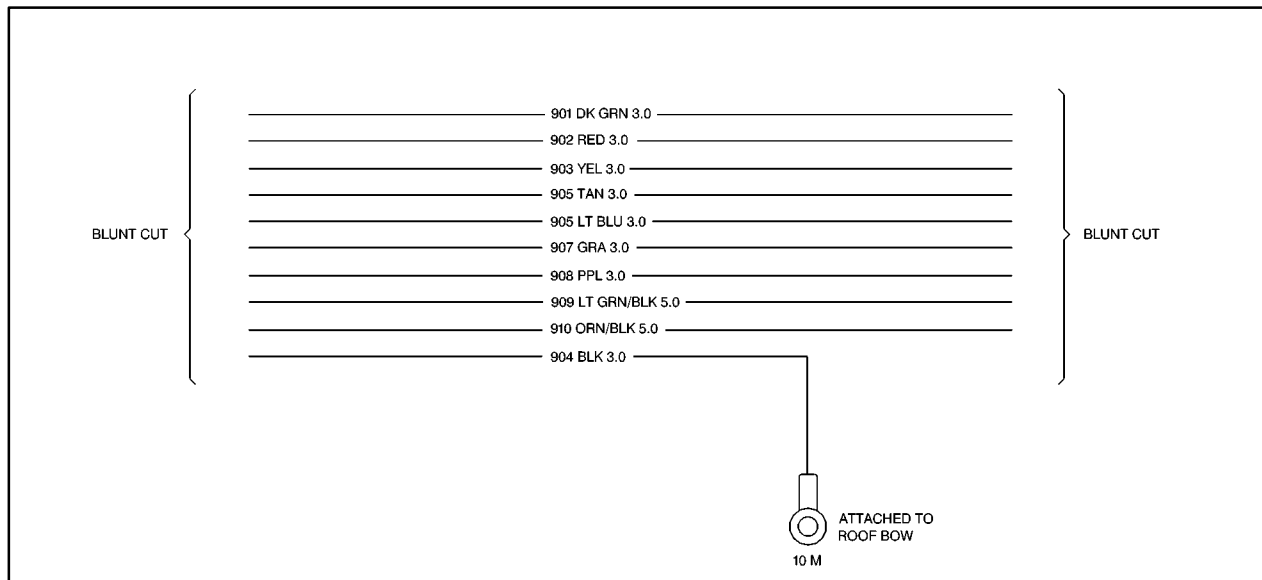

**Wiring Diagram for SEO 6F5**

## Wiring Provisions Front Speakers -- SEO WX7

Approximately 42 inches (107 cm) of auxiliary speaker wire is run from the instrument panel radio connector and coiled under the center of the instrument panel. The wiring permits the connection of front door speakers to customer installed communication equipment.

### Electrical Connections

1. Disconnect the negative (-) battery cable at the battery.
2. Remove the tape from the wire coiled under the instrument panel to uncoil it.
3. Using proper electrical connectors connect the wires with the marker tape stamped LT FRT SPKR to the left audio output of the customer installed communication device.
4. Using proper electrical connectors, connect the wires with the marker tape stamped RT FRT SPKR to the right audio output of the customer installed communication device. The impedance capacity of each speaker installed is 10 ohms.

### NOTICE:

**If you do not turn off electrical accessories such as the windshield wiper switch or the radio, they could be damaged. Turn off all electrical accessories before attaching cables to the battery.**

5. The ignition must be turned off and the vehicle must be vacated prior to attaching the cables to the battery.
6. Connect the negative (-) battery cable to the battery and tighten the bolt to 11 lb-ft (15 N·m). Set the clock time, radio pushbuttons and the Theft-Deterrent feature as needed. See “Audio Systems” in the Owner’s Manual.

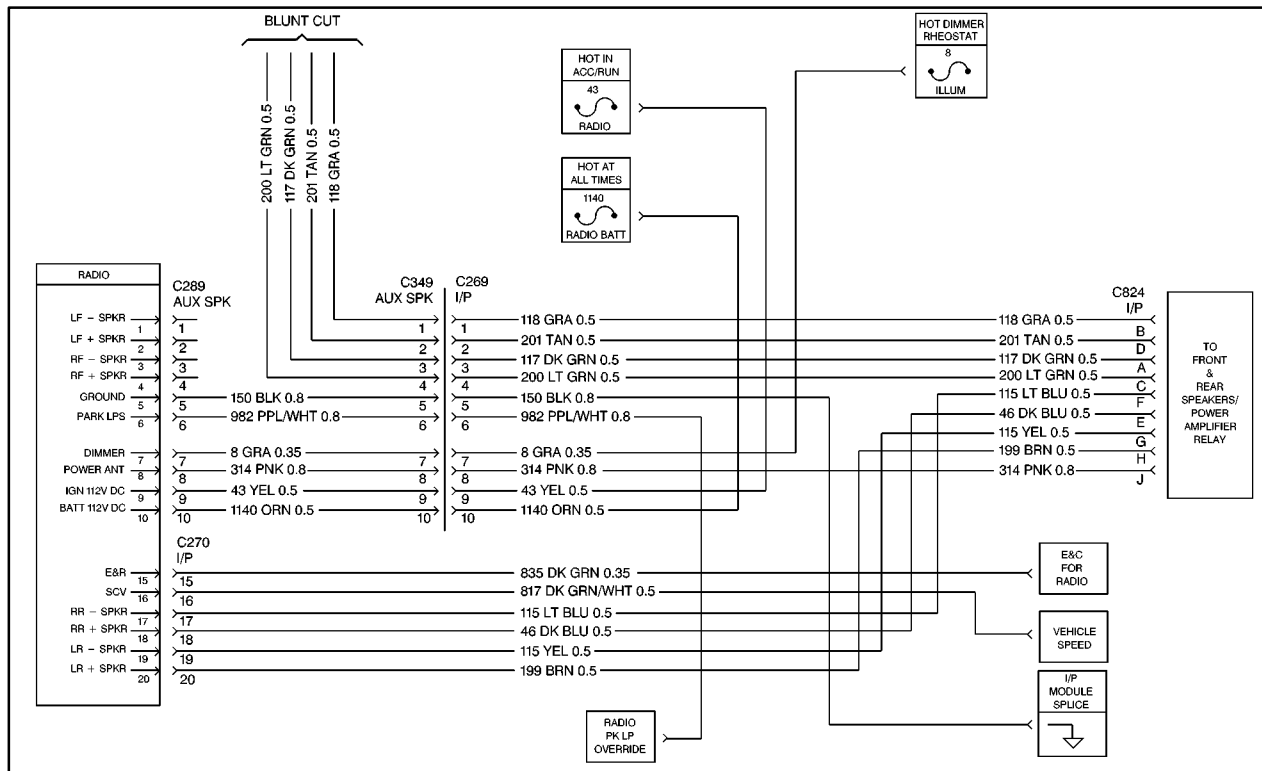

Wiring Diagram for SEO WX7

## Section 12 Index

---

- A**lternate Key Codes ..... 2-1  
 Alternating Signal Flasher ..... 10-10  
 Auxiliary Battery Power ..... 10-12  
 Auxiliary Dome Lamp ..... 11-2  
 Auxiliary Light Switch ..... 10-6
- B**attery, Auxiliary Power ..... 10-12  
 Battery, Dual ..... 6-1  
 Brake, Adjustment ..... 6-1  
 Brakes ..... 6-1
- C**hanging a Flat Tire ..... 5-1  
 Check Gages Light ..... 2-5  
 Cinch Feature, Lap Belt ..... 1-1
- D**aytime Running Lamps ..... 2-2  
 Daytime Running Lamps Off Switch ..... 2-2  
 Door  
   Inactive Rear Locks ..... 2-1  
   Locks ..... 2-1  
 Dual Battery System ..... 6-1
- E**lectrical Connection Notice ..... 10-1, 11-1  
 Engine, Running While Parked ..... 2-2
- F**eatures and Controls ..... 2-1  
 Flat Tire, Changing ..... 5-1
- G**ages  
   Speedometer ..... 2-5  
   Tachometer ..... 2-5
- I**nstrument Panel Cluster ..... 2-4
- K**eys ..... 2-1
- L**amps ..... 2-2  
   Daytime Running ..... 2-2  
   Daytime Running Off Switch ..... 2-2  
 Lap Belt Cinch Feature ..... 1-1  
 Light, Check Gages ..... 2-5  
 Locks ..... 2-1  
   Door ..... 2-1  
   Inactive Rear Door ..... 2-1  
   Spare Tire ..... 5-1
- M**ega Fuse Block ..... 10-13, 10-14

<b>O</b> dometer .....	2-5
Odometer, Trip .....	2-5
<b>P</b> roblems on the Road .....	5-1
<b>R</b> oof Mounted Accessories Light Switch .....	10-6
Running Your Engine While Parked .....	2-2
<b>S</b> afety Belt, Lap Belt Cinch Feature .....	1-1
Seats and Restraint Systems .....	1-1
<b>S</b> EO	
6A5 .....	2-1
6C7 .....	11-2
6E2 .....	2-1
6E8 .....	2-1
6F5 .....	11-12
6J1 .....	11-2
6J4 .....	11-10
6N6 .....	2-1
7X6 .....	11-7
7X7 .....	11-7
7X8 .....	11-7
7X9 .....	11-7
8A0 .....	5-1
8Y9 .....	6-1
WX7 .....	11-15

Service and Appearance Care .....	6-1
Servicing Relays and Circuit Breakers .....	11-5
Servicing Relays and Fuses .....	10-4
Speaker Specifications .....	11-15
Speakers, Wiring Provisions .....	11-15
Specific Cylinder Unit for Single Key System .....	2-1
Speedometer .....	2-5
Spotlamp Installation .....	11-8
Spotlamp Provision(s) .....	11-7
Spotlamp(s) .....	11-7

<b>T</b> achometer .....	2-5
Trailer Towing .....	4-1
Trip Odometer .....	2-5

<b>W</b> arning Lights, Gages and Indicators .....	2-5
Wiring Provisions	
Front Speakers .....	11-15
Horn/Siren Circuit .....	11-10
Roof Mounted Accessories .....	10-6, 11-12
Twelve-Volt Power Supply .....	10-2, 11-2
Vehicle Grille Lamps and Speaker .....	10-10

<b>Y</b> our Driving and the Road .....	4-1
---	-----