

2006 Hybrid Owner Manual

Seats and Restraint System	1-1	Service and Appearance Care	5-1
Airbag System	1-2	Service	5-3
Restraint System Check	1-2	Checking Things Under the Hood	5-4
Features and Controls	2-1	Electrical System	5-20
Features and Controls	2-2	Tires	5-24
Starting and Operating Your Vehicle	2-8	Capacities and Specifications	5-28
Instrument Panel	3-1	Maintenance Schedule	6-1
Climate Controls	3-2	Maintenance Schedule	6-2
Driver Information Center (DIC)	3-2	Index	1
Driving Your Vehicle	4-1		
Your Driving, the Road, and Your Vehicle	4-2		
Towing	4-2		

GENERAL MOTORS, GM and the GM Emblem, CHEVROLET, the CHEVROLET Emblem, GMC, the GMC Emblem, and the names SILVERADO and SIERRA are registered trademarks of General Motors Corporation.

The information in this manual supplements the owner manual. This manual includes the latest information available at the time it was printed. We reserve the right to make changes in the product after that time without notice.

Please keep this manual with the owner manual in your vehicle, so it will be there if you ever need it while you are on the road. If you sell your vehicle, leave this manual and the owner manual with the vehicle.

Introduction

Your hybrid pickup truck is designed to be more fuel efficient than the standard pickup truck, which results in reduced carbon dioxide emissions. Your new vehicle also features a 120-volt (2,400 watt) auxiliary power outlet system, enabling you to power most electrical/electronic devices.

Warranty Information

For vehicles sold in the United States, in addition to the Bumper-to-Bumper Coverage described in the Warranty Booklet, General Motors will warrant certain Hybrid components for each 2006 Chevrolet Silverado Hybrid and GMC Sierra Hybrid (hereafter referred to as Hybrid) for 8 years or 100,000 miles (160 000 kilometres), whichever comes first, from the original in-service date of the vehicle, against warrantable repairs to the specific Hybrid components of the vehicle. For vehicles sold in Canada, in addition to the Complete Vehicle Coverage described in the GM TOTAL Warranty, Maintenance and Owner Assistance Booklet, General Motors of Canada Limited will warrant certain Hybrid components for each 2006 Chevrolet Silverado Hybrid and GMC Sierra Hybrid (hereafter referred to as Hybrid) for 8 years, or 160,000 kilometres, whichever comes first, from the original in-service date of the vehicle, against warrantable repairs to the specific Hybrid components of the vehicle.

In addition to the initial owner of the vehicle, the coverage described in this Hybrid warranty is transferable at no cost to any subsequent person(s) who assumes ownership of the vehicle within the above described 8 year or 100,000-mile (160 000 kilometres) term. No deductibles are associated with this Hybrid warranty.

This Hybrid warranty is in addition to the express conditions and warranties described in the Warranty Booklet. The coverage and benefits described in the Warranty Booklet under “New Vehicle Limited Warranty” are not extended or altered because of this special Hybrid Component Warranty.

For 2006 Hybrid owners requiring more comprehensive coverage than that provided under this Hybrid warranty, a GM Protection Plan may be available. See your Chevrolet or GMC Dealer for more details.

What is Covered

This hybrid warranty covers repairs to correct any vehicle defect related to materials or workmanship occurring during the 8 year or 100,000 mile (160 000 kilometres) term for the following:

Transmission

All automatic transmission components including the auxiliary transmission fluid pump assembly, flexplate assembly, electric machine rotor and stator.

Steering

Electrohydraulic power steering pump and reservoir.

Brakes

Brake apply system sensor on the brake pedal assembly.

Other Hybrid Components

Starter generator control module, SGCM radiator, SGCM coolant pump and bottle; Energy storage box and components including batteries and control module; hood switch, electric power outlets, 3 phase cable assembly, hybrid control module.

Towing

During the 8-year or 100,000 mile (160 000 kilometres) Hybrid warranty period, towing is covered to the nearest Chevrolet or GMC Hybrid servicing dealer if your vehicle cannot be driven because of a warranted defect. Contact the Chevrolet or GMC Roadside Assistance Center for towing. Refer to the Warranty Booklet for details.

Courtesy Transportation

During the 8-year or 100,000 mile (160 000 kilometres) Hybrid warranty period, interim transportation may be available under the Chevrolet or GMC Courtesy Transportation Program. Please consult your dealer for details.

What is Not Covered

In addition to the “What is Not Covered” section of the Warranty Booklet, this Hybrid warranty does not cover the following items:

Wear Items

Wear items, such as brake linings, are not covered in this Hybrid warranty.

Maintenance

As the vehicle owner, you are responsible for the performance of the scheduled maintenance listed in your owner’s manual. Maintenance intervals, checks, inspections, and recommended fluids and lubricants as prescribed in the owner’s manual are necessary to keep your vehicle in good working condition. Any damage caused by owner/lessee failure to follow scheduled maintenance may not be covered by warranty. Scheduled maintenance includes such items as:

- Filters
- Coolants and Fluids
- Brake Pads / Linings

How to Use This Supplement

This supplement contains information specific to the restraint system, auxiliary power outlet system, hybrid cooling system, and fuel system on your vehicle. It does not explain everything you need to know about your vehicle. You must use this supplement along with your GM owner manual. Only then will you be able to properly operate and maintain your vehicle. Many people read their owner’s manual supplement from beginning to end when they first receive their new vehicle. If you do this, it will help you learn about the features and controls for your vehicle. In this supplement, you will find that pictures and words work together to explain things quickly.

Index

A good place to look for what you need is the Index in back of this supplement. It is an alphabetical list of what is in the supplement, and the page number where you will find it.

Section 1 Seats and Restraint System

Airbag System	1-2	Restraint System Check	1-2
What Will You See After an Airbag Inflates?	1-2	Replacing Restraint System Parts	
		After a Crash	1-2

Airbag System

What Will You See After an Airbag Inflates?

After an airbag inflates or if there is a right side impact, the automatic battery disconnect will open and the 42-volt battery will be disconnected. The 42-volt electrical power to the vehicle will be off and the vehicle will not start. To operate the vehicle, the automatic battery disconnect must be reconnected by a qualified service technician at your dealership. Have your vehicle serviced right away.

Restraint System Check

Replacing Restraint System Parts After a Crash

If you have been in a collision in which the right side of your vehicle has been hit, your vehicle's sensing system may alert the automatic battery disconnect to open. The battery will disconnect. The 42-volt electrical power to the vehicle will be off and the vehicle will not start. The airbag readiness light will come on. See "Airbag Readiness Light" in the Index of your owner manual. To operate your vehicle, the automatic battery disconnect must be reconnected by a qualified service technician and sensing system parts will need to be replaced. Have your vehicle serviced right away.

Section 2 Features and Controls

Features and Controls	2-2	Starting and Operating Your Vehicle	2-8
Auxiliary Power Outlet (APO) System	2-2	Starting Your Vehicle	2-8

Features and Controls

Auxiliary Power Outlet (APO) System

The Auxiliary Power Outlet (APO) system provides up to 2,400 watts of 120-volt AC power. With these power outlets, you can plug in most auxiliary electrical equipment and devices with a maximum limit of 2,400 watts. If you try to use equipment that requires more than the limit, a 20-amp protection circuit will cut the power supply and a light in the APO switch will flash along with a Driver Information Center (DIC) message that will flash 120V OVERLOAD. Once this occurs, the system must be reset. See “Resetting the Short Circuit, Overload or Ground Fault Detection (GFD) Circuit” later in this section and *DIC Warnings and Messages on page 3-2* for more information.

When running APO, do not have the front of the vehicle obstructed. Leave at least five feet (1.5 m) of space between the front of the vehicle and any other object. This will allow airflow through the radiator and help to keep the SGCM cooler.

There are outlets located inside the cabin and in the truck bed.

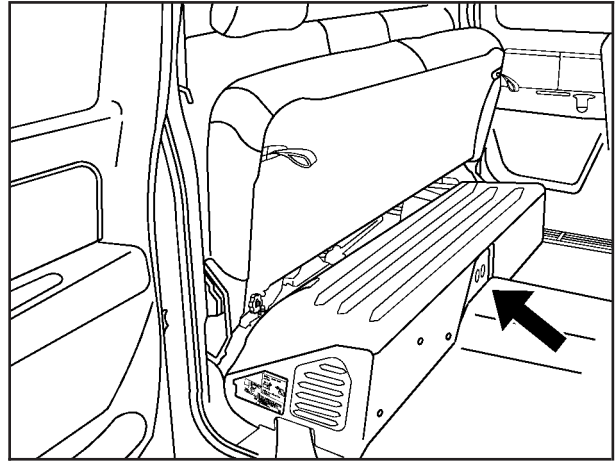

Inside the vehicle, they are in the middle of the rear seat near the bottom.

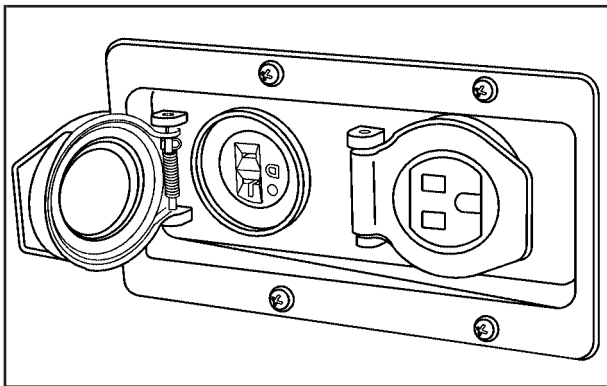

In the truck bed, they are located on the passenger side near the tailgate.

The power outlets are not designed for equipment with high initial peak starting power of greater than 2,400 watts, such as some air compressors, table saws, etc.

Short Circuits, Overloads and Ground Fault Detection (GFD)

The 120-volt AC power outlets are protected against short circuits, overloads and ground faults. If the system detects a short or overloaded circuit, it will immediately shut down the outlets and the light next to the APO button will flash, while at the same time a 120V OVERLOAD message will appear in the Driver Information Center (DIC). After the fault condition is corrected, the system can be reset by pressing and releasing the APO button. See “APO Operating Modes” for more information on the APO button. Short circuits may occur because a defective extension cord or defective electrical device is plugged into an outlet.

Some electrical devices, such as motor-driven appliances and tools, have high start-up currents. During this start-up period, the 120-volt AC supply will attempt to start the electrical device for up to 5 seconds. If the current does not fall below the maximum 20 amp rating of the APO within this 5-second timeframe, the system will shut down the outlets and the light next to the APO button will flash, while at the same time a 120V OVERLOAD message in the DIC will appear. This type of situation is unlikely, but if it does happen, press the APO button and try to start the electrical device again. If the electrical device fails to start a second time, it is probably because the device needs more start-up power than is available.

The Ground Fault Detection (GFD) system checks for leakage current to ground, or the truck frame, that could potentially be a shock hazard, in much the same way as the Ground Fault Circuit Interrupt (GFCI) outlets protect you in your home. The GFD self-test is automatically performed during the activation of the APO system. Thereafter, if the GFD system detects a significant leakage current, it will immediately shut down the outlets and the light next to the APO button will flash, while at the same time a 120V GROUND FAULT message will appear in the DIC. If this happens, unplug all electrical devices and reset the system by pressing the APO button. Then plug in each electrical device individually until the malfunctioning extension cord or electrical device is identified.

If, after unplugging all electrical devices and cords and resetting the system, either the 120V OVERLOAD message or the 120V GROUND FAULT message continues to be displayed, have the vehicle serviced.

APO Operating Modes

The APO system is capable of being operated in two different modes:

- **Normal mode:** This is used while the vehicle is running and in PARK (P), the vehicle is in Auto-Stop mode, or the vehicle is moving.
- **Continuous mode:** This is used while the vehicle is parked.

Normal Mode

This mode can be activated while in any transmission gear position to supply the outlets with 2,400 watts of 120-volt AC power.

To activate the normal mode do the following:

1. Start the engine. See “Starting Your Engine” in the owner manual Index.

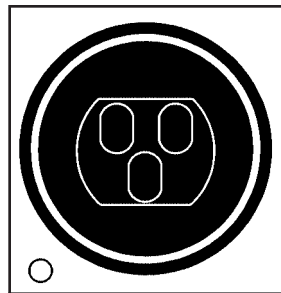

2. Press and release the APO button, located on the instrument panel, once. Do not hold the APO button for more than two seconds.

The light next to the APO button will come on, indicating that the system is supplying 120-volt AC power to the outlets.

3. Connect your electrical/electronic device(s) to the outlets. Be sure the device(s) is secure so you can drive the vehicle safely. If you must use extension cords, be sure to use only UL[®] approved extension cords.

If the system stops supplying 120-volt AC power unexpectedly and the APO button starts flashing, the system has detected an overload or ground fault condition. To reset the system see “Resetting the Short Circuit, Overload or Ground Fault Detection (GFD) Circuit” later in this section.

The APO system will operate in the normal mode until you turn it off by doing one of the following:

- Pressing the APO button. The light in the APO button will turn off.
- Turning the ignition switch to ACCESSORY or LOCK. See “Ignition Positions” in your owner manual Index.

Continuous Mode

This mode can be operated only when the vehicle is not moving and the transmission is in PARK (P) and will provide up to 2,400 watts of 120-volt AC power to the outlets.

Continuous mode can be operated with the key removed from the ignition. The engine will run continuously in this mode to supply electrical power to the APO system.

You can use the vehicle as a generator in this mode when no electrical power outlets are available or during instances such as power outages.

Use this mode to power critical appliances rather than an entire circuit in a home/building. Never connect the APO system outlets directly to a building’s circuitry or another power supply.

For more information on running your vehicle while it is parked, see “Parking Over Things that Burn,” “Engine Exhaust,” and “Running Your Engine While You Are Parked” in your owner manual Index.

To activate the continuous mode, do the following:

1. Place the transmission in PARK (P) with the ignition in RUN and the engine running. See “Ignition Positions” in your owner manual Index.

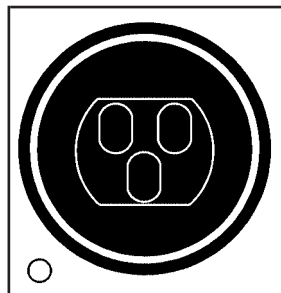

2. Press and hold the APO button, located on the instrument panel, for longer than two seconds. The light next to the APO button should begin to flash and the DIC message, 120V READY will appear.

3. Turn the ignition key to LOCK while the light is flashing. The light will flash for up to 30 seconds. When the ignition key has been turned to LOCK, the light next to the APO switch will stop flashing and remain on. The engine will continue to run.
4. Connect your 120-volt AC electrical/electronic device(s) to the outlets. If you must use extension cords, be sure to use only UL[®] approved extension cords.

You can remove the key from the ignition at this point.

⚠ CAUTION:

Leaving children in a vehicle with the ignition key is dangerous for many reasons. They could operate the power windows or other controls or even make the vehicle move. The children or others could be badly injured or even killed. Do not leave the keys in a vehicle with children.

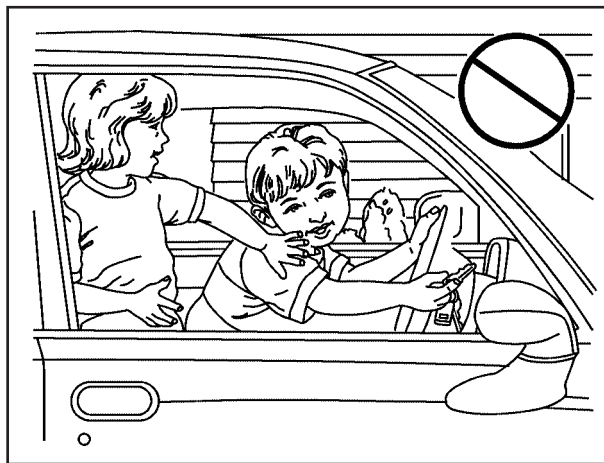

If the system stops supplying 120-volt AC power unexpectedly and the light next to the APO button starts flashing, the system has detected an overload or ground fault condition. To reset the system see “Resetting the Short Circuit, Overload or Ground Fault Detection (GDF) Circuit” later in this section.

The APO system will operate in the continuous mode with the engine running until one of the following occurs:

- You press the APO button. The light in the APO button will turn off and the engine will turn off.
- If the fuel level gets low.

A FUEL LEVEL LOW message will appear in the DIC and the horn will sound intermittently for five seconds every minute for five minutes.

If the vehicle is left unattended for the full five minute warning, the engine and APO system will shut down, unless the APO button is pressed during the five minute warning period. See *DIC Warnings and Messages on page 3-2* for more information on the FUEL LEVEL LOW message.

- An overload or ground fault condition is detected and not reset in five minutes.
- Vehicle security is violated.
- Engine oil pressure becomes too low.
- Engine coolant temperature becomes too hot.

- The ignition key is moved out of LOCK.

This may display an OIL PRESSURE LOW DIC warning message and chimes which is a normal condition when the APO button was not used to shut off the continuous mode.

- The hybrid power system becomes too hot.

Resetting the Short Circuit, Overload or Ground Fault Detection (GFD) Circuit

To reset the Short Circuit, Overload or Ground Fault Detection (GFD) Circuit while operating in both the normal and continuous modes, ensure any observed fault is removed, and press the APO button. The light next to the button will illuminate indicating that the system is supplying 120-volt AC power to the outlets. In the case of an engine shutdown due to a ground fault while in the continuous mode, restart the engine by turning the key from LOCK to START, then follow the instructions for entering APO Continuous Mode earlier in this section.

Starting and Operating Your Vehicle

Starting Your Vehicle

CAUTION:

There is something about your vehicle that can make it move suddenly, and you or others can be seriously injured. This can happen if the vehicle is in the Auto Stop mode, and the shift lever is in DRIVE (D). Because your vehicle has the Automatic Engine Start/Stop feature, your vehicle's engine might seem to be shut off when you come to a complete stop. However, if you then start to exit the vehicle, as soon as you take your foot off the brake pedal, the engine will start again and the vehicle can move forward. If you are going to exit your vehicle, first shift to PARK (P) and turn the ignition to LOCK. Then exit.

Your vehicle has an automatic engine start/stop feature. This feature can cause the engine to turn off when you are applying the brake and going less than 13 mph (21 km/h), or when you come to a complete stop. When you take your foot off the brake pedal, the engine will start again and you will continue forward. However, if you are on an incline, your vehicle may roll backwards a short distance until the engine performs the auto start. To be sure your vehicle will not move or roll, always keep your foot firmly on the brake pedal until you are ready for the vehicle to move.

Start the engine just as you would any normal engine. Also see "Starting Your Engine" in the Index of the owner manual for more information on starting. After the engine is started and has reached operating temperature, it will shut off automatically when bringing the vehicle to a stop — usually the engine will shut off before a complete stop if you are braking at speeds below about 13 mph (21 km/h). If you are pulling a trailer and your trailer is equipped with trailer brakes, see *Towing a Trailer on page 4-2* for more information.

To restart the engine during the auto stop, release the brake pedal and the engine will start immediately. The vehicle will operate as a normal vehicle, until the next stop.

Automatic Engine Start/Stop Override

The automatic engine start/stop override feature may cause the engine to remain running at a complete stop or may start the engine at a complete stop. The following are reasons why either of these conditions may be encountered.

The engine will stay running at a complete stop or will automatically start from a complete stop if:

- The outside temperatures are high — usually above 95°F (35°C). The climate control system is working to cool the cabin in AUTO mode. See *Climate Controls on page 3-2*.
- You release the brake pedal in DRIVE (D) or THIRD (3) — even slightly.
- The shift lever is in NEUTRAL, REVERSE (R), SECOND (2) or FIRST (1).
- The battery pack charge is low.
- The tow/haul mode is active.
- The transfer case is in 4LO.
- The brake pedal has been released for more than three seconds while the vehicle is in PARK (P).
- It is necessary to maintain 120-volt APO operation for loads greater than 1kw.
- The hood is not fully closed.

Manual Override System

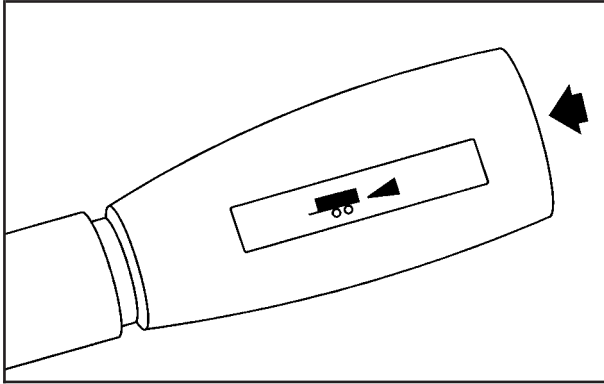

To manually override the automatic engine start/stop system, press the tow/haul switch, located on the end of the column shift lever.

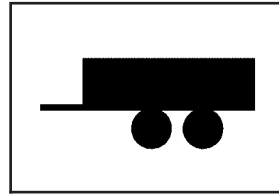

When the tow/haul mode has been activated, this light will come on in the instrument cluster.

This system disables the engine from performing the auto stop function. While not required, you might choose to use this during frequent start/stops, while driving on grades or in heavy traffic.

Press the tow/haul switch again, or turn the ignition off, to enable the auto stop function. The indicator light on the cluster will go out.

Climate Controls

For more information on your vehicle's climate control system, see "Climate Control System" in the owner manual Index.

Air Conditioning Engine Start/Stop Override

With the system in AUTO mode in warm or hot weather, the engine may continue to run at a complete stop, or it may re-start during a complete stop if the system determines that it is necessary to run the air conditioning compressor to cool the cabin and/or dehumidify the air.

The system may allow the engine to shut off if the cabin temperature selected is met, but engine off time will usually be short.

If you would like to get maximum engine off time in hot weather, select manual operation for vent or bi-level mode; this will prevent the system from keeping the engine running at complete stops; however, this does not provide maximum air conditioning performance.

Selecting a higher air conditioning temperature in hot weather will maximize engine off time.

Driver Information Center (DIC)

DIC Warnings and Messages

Warning messages are displayed on the DIC to notify the driver that the status of the vehicle has changed and that some action may be needed by the driver to correct the condition. If there is more than one message that needs to be displayed they will appear one after another. Some messages may not require immediate action but you should press the select button or the trip odometer reset stem on the instrument panel cluster to acknowledge that you received the message and clear it from the display. Some messages cannot be cleared from the display because they are more urgent; these messages require action before they can be removed from the DIC display. The following are the possible messages that can be displayed and some information about them. For information on other DIC messages, see "DIC Warnings and Messages" in the owner manual Index.

42V SWITCH OFF

When a fuse in the 42-volt battery system is blown, the battery cut off (BCO) switch is open or the battery disconnect switch is open, this message will appear. It will clear when the problem is fixed, when the battery disconnect switch is closed or by pressing the DIC select button or the trip reset stem on the instrument panel cluster. The fuse on the 42-volt battery pack can only be replaced and the automatic battery disconnect can only be closed by a qualified service technician. See *Fuses and Circuit Breakers on page 5-22* and *Battery Disconnect Switch on page 5-20* and “Instrument Panel Cluster” in the owner manual Index for more information.

120V DISABLED

This message will display when the hybrid’s power system is too hot to function in the APO normal mode. This message will display for 10 seconds or until the system cools down. This message will also display for 10 seconds each time the APO is activated while the system is too hot to function. See “Normal Mode” under *Auxiliary Power Outlet (APO) System on page 2-2*.

120V GROUND FAULT

This message will display when the APO normal or continuous mode turns off due to an electrical ground fault.

When in the normal mode, the message will display for 10 seconds.

When in the continuous mode, the engine will continue to run for five minutes after a ground fault condition is identified and the APO is not reset. The message will be displayed the entire time the engine is running. See “Resetting the Short Circuit, Overload or Ground Fault Detection (GFD) Circuit” under *Auxiliary Power Outlet (APO) System on page 2-2*.

120V OVERLOAD

This message will display when the APO normal or continuous mode turns off due to an electrical overload fault.

When in the normal mode, the message will display for 10 seconds.

When in the continuous mode, the engine will continue to run for five minutes after an overload condition is identified and the APO is not reset. The message will be displayed the entire time the engine is running. See “Resetting the Short Circuit, Overload or Ground Fault Detection (GFD) Circuit” under *Auxiliary Power Outlet (APO) System on page 2-2*.

120V READY

This message will display and the light in the APO button will flash when the system is ready/waiting to enter the continuous mode for 30 seconds or until the ignition is turned to LOCK. See “Continuous Mode” under *Auxiliary Power Outlet (APO) System on page 2-2*.

120V SYSTEM FAULT

This message will display when the APO normal or continuous mode turns off due to a system fault.

When in the normal mode, the message will display for 10 seconds.

When in the continuous mode, the message will display for 60 seconds and the engine will turn off. It will also display for 10 seconds the next time the engine is started until the problem is fixed. See *Auxiliary Power Outlet (APO) System on page 2-2*.

BATTERY NOT CHARGING

If the hybrid battery system faults or fails (42-volt or 12-volt system), this message will appear on the DIC. The engine auto start/stop feature will be disabled and the battery/charging system light will appear in the instrument panel cluster. See “Battery Warning Light” in the owner manual Index.

Driving with this light on could drain your batteries. Have the electrical system checked as soon as possible. Pressing the select button or the trip odometer reset stem on the instrument panel cluster will acknowledge this message and clear it from the DIC display.

ENGINE AUTO START MODE

When the vehicle is in PARK (P) and the auto stop function is active, this message will display to let you know that the engine may start automatically at any given time. This message will clear when the vehicle is taken out of PARK (P), if the key is turned to LOCK, or when the engine auto starts.

Pressing the DIC select button or the trip odometer reset stem on the instrument panel cluster will also clear the message.

ENGINE COOLANT HOT

If the engine cooling system temperature gets hot, this message will appear on the DIC. Stop the vehicle and let the engine idle in PARK (P) to allow the coolant to reach a safe temperature. This message will clear when the coolant temperature drops to a safe operating temperature. See “Cooling System” in the owner manual Index for more information.

The APO continuous mode will also stop operating when this message comes on. See “Continuous Mode” under *Auxiliary Power Outlet (APO) System on page 2-2*.

FUEL LEVEL LOW

If the fuel level is low while the APO system is in continuous mode, this message will appear on the DIC and the horn will sound for five seconds every minute for five minutes. Refuel as soon as possible. If the vehicle is left unattended for the full five minute warning, the engine and APO system will shut down, unless the APO button is pressed during the five minute warning period. See “Continuous Mode” under *Auxiliary Power Outlet (APO) System on page 2-2*.

Pressing the select button or the trip odometer reset stem on the instrument panel cluster will acknowledge this message immediately and clear it from the DIC display. It will also clear itself after five minutes. The low fuel light near the fuel gage will still remain on in either case. See “Fuel Gage” and “Instrument Panel Cluster” in the owner manual Index.

HOOD AJAR

If the hood is not fully closed, this message will appear on the display. Close the hood to clear the message. Pressing the select button or the trip stem on the instrument panel cluster will acknowledge this message and clear it from the DIC display also.

When this message is displayed, the auto start/stop function will not operate with the hood open. If the vehicle is in auto stop mode when this message appears, you will have to restart the engine with the ignition key. See *Starting Your Vehicle on page 2-8*.

OIL PRESSURE LOW

If engine oil pressure is low, this message will be displayed on the DIC. Stop the vehicle as soon as safely possible and do not operate it until the cause of the low oil pressure has been corrected. Check your oil as soon as possible and have your vehicle serviced. See “Engine Oil” in the owner manual Index.

The APO continuous mode will stop operating when this message comes on. The message will reappear for 60 seconds when the vehicle is shut off and 10 seconds when restarted to let you know why the APO continuous mode was canceled. See “Continuous Mode” under *Auxiliary Power Outlet (APO) System on page 2-2.*

SECURITY

This message, along with the security light on the instrument panel cluster, will appear on the DIC for 60 seconds when a security violation has occurred. The APO continuous mode will cancel at this time. See “Theft-Deterrent Systems” in the owner manual Index.

SERVICE 42V BATTERIES

This message will display when the 42-volt batteries need service or replacement due to age or if a failure condition is present. This message will be displayed for 10 seconds and then will display again each time the ignition key is turned from LOCK to RUN. See *Battery on page 5-13* for more information.

SERVICE BRAKE SYSTEM

If you hear four short chimes along with the brake system warning light and this message alternating with the SERVICE STEER SYSTEM message, the power assist system is not working. You will still be able to steer and brake, but it will be much more difficult. Pull off the road to a safe location and have your vehicle towed to the nearest dealer for service. See “Brakes,” “Brake System Warning Light,” and “ABS Brake System Warning Light” in the owner manual Index.

SERVICE STEER SYSTEM

If the SERVICE STEER SYSTEM message is displayed without any chimes, the power assist system will continue to function, but it may be more difficult to steer. Have the steering system serviced as soon as possible. Also, see “SERVICE BRAKE SYSTEM” listed previously.

Section 4 Driving Your Vehicle

Your Driving, the Road, and Your Vehicle	4-2	Towing	4-2
Regenerative Braking	4-2	Towing a Trailer	4-2

Your Driving, the Road, and Your Vehicle

Regenerative Braking

Your vehicle has a regenerative braking system. This system works whenever you take your foot off the accelerator pedal while your vehicle is moving in DRIVE (D). This causes your vehicle to slow down slightly faster. It may feel like the brake pedal is being pressed, even when it is not.

Regenerative braking takes some of the energy from the moving vehicle and turns it back into electrical energy. This energy is then stored back into the vehicle's 42-volt battery system, contributing to increased fuel efficiency.

Towing

Towing a Trailer

For more information, see "Towing a Trailer" in your owner manual Index.

Weight of the Trailer

How heavy can a trailer safely be?

It depends on how you plan to use your rig. For example, speed, altitude, road grades, outside temperature and how much your vehicle is used to pull a trailer are all important. And, it can also depend on any special equipment that you have on your vehicle.

Use the charts following to determine how much your vehicle can weigh, based upon your vehicle model and options.

Maximum trailer weight is calculated assuming the driver and one passenger are in the tow vehicle and it has all the required trailering equipment. The weight of additional optional equipment, passengers and cargo in the tow vehicle must be subtracted from the maximum trailer weight.

Above the 5,000 lbs (2 268 kg) trailer rating, the handling/trailering suspension is required on C-1500 models and the handling/trailering or off-road suspension is required on K-1500 models.

C-1500 Extended Cab Short Box (2WD)			
Vehicle	Axle Ratio	Maximum Trailer Weight	GCWR
5300 V8	3.23	6,700 lbs (3 039 kg)	12,000 lbs (5 443 kg)
	3.73	7,700 lbs (3 493 kg)	13,000 lbs (5 897 kg)
Hybrid vehicles are neither designed nor intended to tow fifth-wheel or gooseneck trailers.			

K-1500 Extended Cab Short Box (4WD)			
Vehicle	Axle Ratio	Maximum Trailer Weight	GCWR
5300 V8	3.42	7,400 lbs (3 357 kg)	13,000 lbs (5 897 kg)
	3.73	7,400 lbs (3 356 kg)	13,000 lbs (5 897 kg)
Hybrid vehicles are neither designed nor intended to tow fifth-wheel or gooseneck trailers.			

The Gross Combination Weight Rating (GCWR) is the total allowable weight of the completely loaded vehicle and trailer including any passengers, cargo, equipment and conversions. The GCWR for your vehicle should not be exceeded.

Trailer Brakes

If you are towing a trailer that is equipped with trailer brakes and you manually apply the trailer brakes while driving slower than 13 mph (21 km/h), your vehicle may go into auto stop mode even if you are not pressing on the vehicle's brakes.

Using the trailer brake system manually can make your hybrid vehicle perform as if you are using the brake pedal in the vehicle. The trailer brake operation check will still work. If you manually apply the trailer brakes for an extended period of time, the SERVICE BRAKE SYSTEM DIC message will come on. The message will go off after the trailer brakes have been released. No other action is necessary. For more information, see "Trailer Brakes" in the owner manual Index.

Section 5 Service and Appearance Care

Service	5-3	Electrical System	5-20
Doing Your Own Service Work	5-3	Battery Disconnect Switch	5-20
Checking Things Under the Hood	5-4	Fuses and Circuit Breakers	5-22
Engine Compartment Overview	5-4	Tires	5-24
Automatic Transmission Fluid	5-6	Changing a Flat Tire	5-24
SGCM Coolant Surge Tank Pressure Cap	5-6	Capacities and Specifications	5-28
Cooling System	5-7		
Power Steering Fluid	5-12		
Battery	5-13		
Jump Starting	5-14		

Service

Doing Your Own Service Work

 **CAUTION:**

Never try to do your own service on hybrid components. You can be injured and your vehicle can be damaged if you try to do your own service work. Service and repair of these hybrid components should only be performed by a GM-trained service technician with the proper knowledge and tools.

Checking Things Under the Hood

Engine Compartment Overview

When you open the hood on your vehicle, you will see the following:

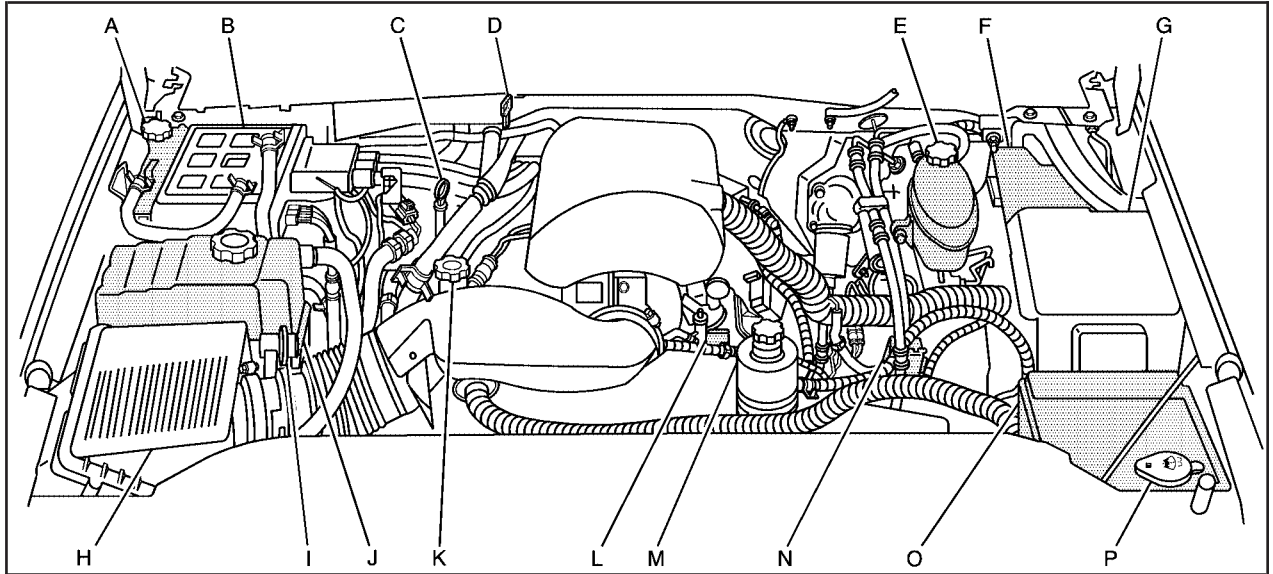

- A. Starter Generator Control Module (SGCM) Coolant Surge Tank. See *Cooling System on page 5-7*.
- B. Starter Generator Control Module (SGCM). See *Cooling System on page 5-7*.
- C. Engine Oil Dipstick. See “Engine Oil” in the owner manual Index.
- D. Automatic Transmission Dipstick. See *Automatic Transmission Fluid on page 5-6*.
- E. Brake Fluid Reservoir. See “Brakes” in the owner manual Index.
- F. Hybrid Underhood Fuse Block. See *Fuses and Circuit Breakers on page 5-22*.
- G. Underhood Fuse Block. See “Underhood Fuse Block” in the owner manual Index.
- H. Engine Air Cleaner/Filter. See “Engine Air Cleaner/Filter” in the owner manual Index.
- I. Air Filter Restriction Indicator (If Equipped). See “Engine Air Cleaner/Filter” in the owner manual Index.
- J. Engine Coolant Surge Tank. See “Cooling System” in the owner manual Index.
- K. Engine Oil Fill. See “Engine Oil” in the owner manual Index.
- L. Remote Negative (–) Terminal (GND). See *Jump Starting on page 5-14*.
- M. Electrohydraulic Power Steering Fluid Reservoir. See *Power Steering Fluid on page 5-12*.
- N. Remote Positive (+) Terminal. See *Jump Starting on page 5-14*.
- O. 12-Volt Battery. See *Battery on page 5-13*.
- P. Windshield Washer Fluid Reservoir. See “Windshield Washer Fluid” in the owner manual Index.

Automatic Transmission Fluid

For more information, see “Automatic Transmission Fluid” in the owner manual Index.

Checking the Fluid Level

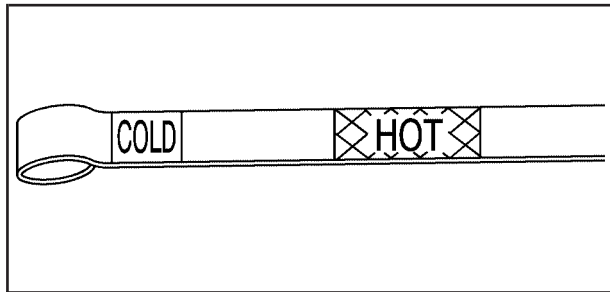

Your vehicle's automatic transmission dipstick looks like this. For more information on location, see *Engine Compartment Overview on page 5-4*.

SGCM Coolant Surge Tank Pressure Cap

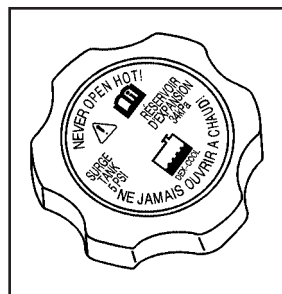

See *Engine Compartment Overview on page 5-4* for more information on location.

The hybrid coolant surge tank pressure cap must be fully installed on the hybrid coolant surge tank.

Notice: If the pressure cap is not tightly installed, coolant loss and possible damage to the Starter Generator Control Module (SGCM) may occur. Be sure the cap is properly and tightly secured.

Cooling System

Starter Generator Control Module (SGCM) Cooling System

In addition to your vehicle's regular cooling system, your vehicle is also equipped with a cooling system for the SGCM system. This system is serviced differently than the vehicle's main cooling system. The SGCM cooling system includes the SGCM coolant surge tank, SGCM surge tank pressure cap, SGCM cooling pump and the Starter Generator Control Module (SGCM). The SGCM cooling system uses the same type of coolant as the vehicle's regular cooling system, but the two systems operate separately and independently. See "Engine Coolant" and "Cooling System" in the Index of the owner's manual for more information.

When you decide it is safe to lift the hood, here is what you will see:

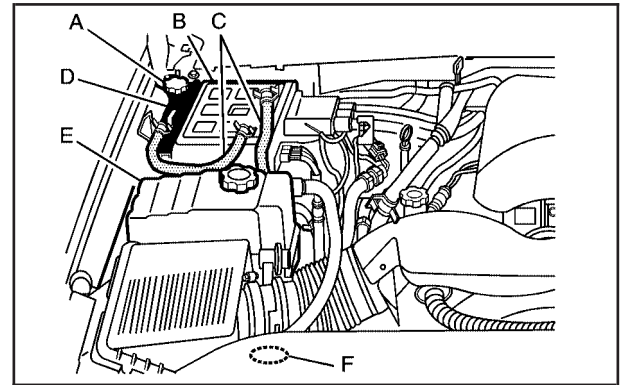

- A. SGCM Coolant Pressure Tank Cap.
- B. Starter Generator Control Module (SGCM).
- C. SGCM Cooling Hoses.
- D. SGCM Coolant Surge Tank.
- E. Engine Coolant Surge Tank and Pressure Cap.
- F. SGCM Cooling Pump (Out of View).

If the coolant inside the SGCM coolant surge tank is boiling, do not do anything else until it cools down.

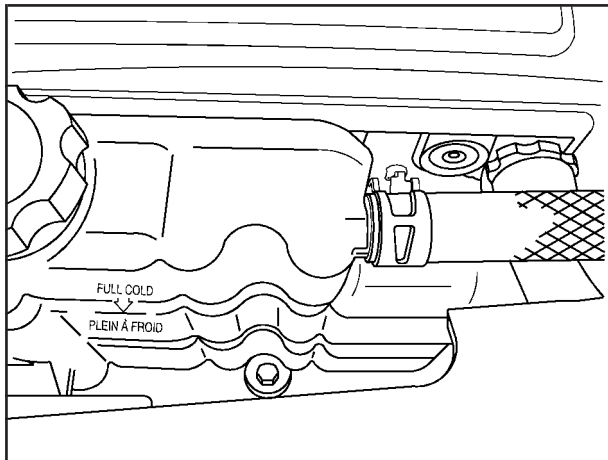

The coolant level should be at or above the FULL COLD mark with the vehicle parked on a level surface. If it is not, you may have a leak at the SGCM heat transfer core, SGCM pressure cap, SGCM auxiliary radiator hoses, SGCM cooling pump or somewhere else in the SGCM cooling system.

Notice: Running the engine when there is a leak in the hybrid cooling system can cause the hybrid cooling system to lose all coolant and can damage the system. Get any leak fixed before you drive the vehicle or run the engine.

How to Add Coolant to the SGCM Coolant Surge Tank

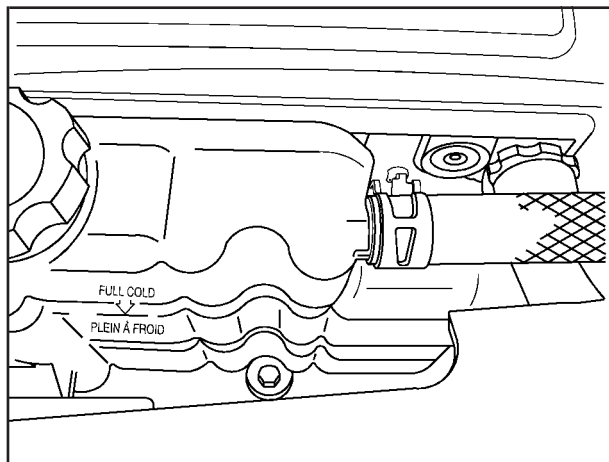

If you have not found a problem yet, check to see if coolant is visible in the SGCM coolant surge tank.

If coolant is visible and within one inch (2.54 cm) of the FULL COLD mark, add a 50/50 mixture of *clean, drinkable water* and DEX-COOL[®] coolant at the SGCM coolant surge tank, but be sure the SGCM cooling system, including the SGCM coolant surge tank pressure cap, is cool before you do it. Use the procedure following.

CAUTION:

Steam and scalding liquids from a hot cooling system can blow out and burn you badly. They are under pressure, and if you turn the coolant surge tank pressure cap — even a little — they can come out at high speed. Never turn the cap when the cooling system, including the coolant surge tank pressure cap, is hot. Wait for the cooling system and coolant surge tank pressure cap to cool if you ever have to turn the pressure cap.

Notice: Using coolant other than DEX-COOL[®] may damage your vehicle. Any repairs would not be covered by your warranty. Always use DEX-COOL[®] (silicate-free) coolant in your vehicle.

⚠ CAUTION:

You can be burned if you spill coolant on hot engine parts. Coolant contains ethylene glycol and it will burn if the engine parts are hot enough. Do not spill coolant on a hot engine.

If the SGCM coolant is more than one inch (2.54 cm) below the FULL COLD mark, your vehicle must be serviced by your dealer and a special fill procedure must be followed.

Notice: Attempting to fill the hybrid cooling surge tank yourself when the fluid level is more than 1 inch (2.54 cm) below the FULL COLD mark can damage your vehicle. Your vehicle must be serviced.

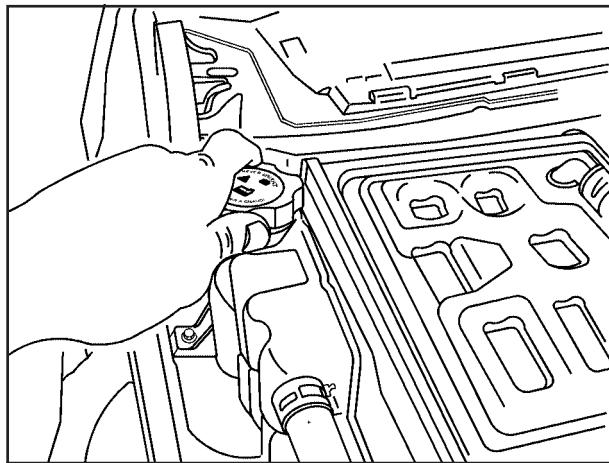

1. Park the vehicle on a level surface and turn the vehicle off. You can remove the SGCM coolant surge tank pressure cap when the SGCM cooling system, including the SGCM coolant surge tank pressure cap and SGCM cooling hoses, are no longer hot. Turn the SGCM coolant surge tank pressure cap slowly counterclockwise (left) about one full turn. Wait 30 seconds.

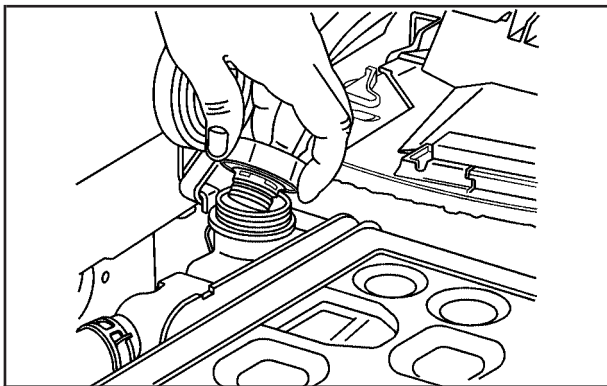

2. Then keep turning the SGCM coolant surge tank pressure cap slowly, and remove it.

3. Add the proper coolant mixture to the SGCM coolant surge tank until the level reaches the FULL COLD mark.

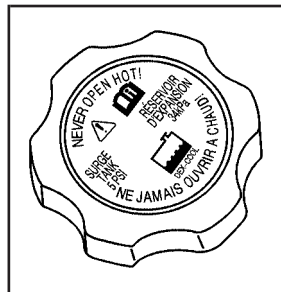

4. Then replace the SGCM coolant surge tank pressure cap. Be sure the pressure cap is hand-tight and fully seated.

Notice: Using cooling system sealers or conditioners in an attempt to stop coolant leaks can damage the SGCM and engine cooling systems. Never use cooling system sealers or conditioners in your cooling system.

Power Steering Fluid

When to Check Power Steering Fluid

It is not necessary to regularly check power steering fluid unless you suspect there is a leak in the system or you hear an unusual noise. A fluid loss in this system could indicate a problem. Have the system inspected and repaired. See *Engine Compartment Overview* on page 5-4 for reservoir location.

How to Check Power Steering Fluid

Turn the key off, let the engine compartment cool down.

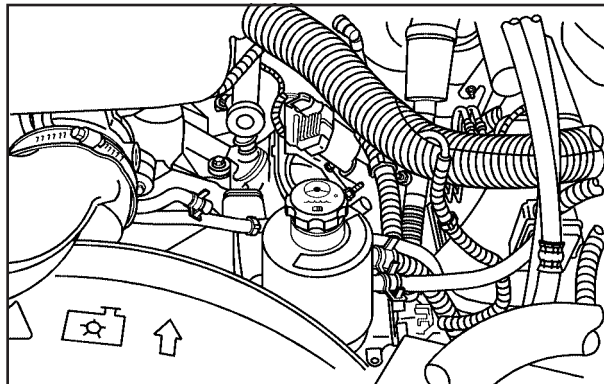

Locate the power steering reservoir and cap. Wipe the cap and the top of the reservoir clean, then unscrew the cap and wipe the dipstick with a clean rag. Replace the cap and completely tighten it. Then remove the cap again and look at the fluid level on the dipstick.

The level should be at the FULL COLD mark. If necessary, add only enough fluid to bring the level up to the mark.

What to Use

To determine what kind of fluid to use, see *Recommended Fluids and Lubricants on page 6-2* for more information. Your hybrid vehicle requires a special power steering fluid. Always use the proper fluid. Failure to use the proper fluid can cause leaks and damage hoses, seals and other steering system parts and repairs may not be covered by your vehicle's warranty.

Battery

Your vehicle has a standard 12-volt battery and a 42-volt hybrid battery system.

When it is time for a new standard 12-volt battery, get one that has the replacement number shown on the original battery's label. We recommend an ACDelco® replacement battery.

When it is time for a new 42-volt hybrid battery system, see your dealer.

Warning: Battery posts, terminals, and related accessories contain lead and lead compounds, chemicals known to the State of California to cause cancer and reproductive harm. Wash hands after handling.

Vehicle Storage

If you are not going to drive your vehicle for 30 days or more you should disconnect your standard 12-volt battery. Remember to reconnect your battery when you are ready to drive your vehicle. You should also disconnect the 42-volt hybrid battery system. See *Battery Disconnect Switch on page 5-20*.

CAUTION:

Batteries have acid that can burn you and gas that can explode. You can be badly hurt if you are not careful. See *Jump Starting on page 5-14* for tips on working around a battery without getting hurt.

Jump Starting

If your 42-volt battery has run down, you may want to use another vehicle's 12-volt battery and jumper cables to start your vehicle. Jump starting your hybrid vehicle may take considerably longer than a regular vehicle. You may have to wait 10 to 20 minutes total for your vehicle to charge from the other vehicle's good 12-volt battery in order to start your vehicle. Use the following steps to do it safely:



CAUTION:

Batteries can hurt you. They can be dangerous because:

- They contain acid that can burn you.
- They contain gas that can explode or ignite.
- They contain enough electricity to burn you.

If you do not follow these steps exactly, some or all of these things can hurt you.

Notice: Ignoring these steps could result in costly damage to your vehicle that would not be covered by your warranty.

Trying to start your vehicle by pushing or pulling it will not work, and it could damage your vehicle.

1. Check to see that the battery disconnect switch on your hybrid vehicle is in the power position. If it is not, turn it clockwise until it stops and then try to start your vehicle. See *Battery Disconnect Switch on page 5-20* for more information. If your vehicle still won't start, continue to Step 2.
2. Check the other vehicle. It must have a 12-volt battery with a negative ground system.

Notice: If the other vehicle's system is not a 12-volt system with a negative ground, both vehicles can be damaged. Only use vehicles with 12-volt systems with negative grounds to jump start your vehicle.

3. Get the vehicles close enough so the jumper cables can reach, but be sure the vehicles are not touching each other. If they are, it could cause a ground connection you do not want. You would not be able to start your vehicle, and the bad grounding could damage the electrical systems.

To avoid the possibility of the vehicles rolling, set the parking brake firmly on both vehicles involved in the jump start procedure. Put an automatic transmission in PARK (P) or a manual transmission in NEUTRAL before setting the parking brake.

Notice: If you leave your radio or other accessories on during the jump starting procedure, they could be damaged. The repairs would not be covered by your warranty. Always turn off your radio and other accessories when jump starting your vehicle.

4. Turn off the ignition on both vehicles. Unplug unnecessary accessories plugged into the cigarette lighter and accessory power outlets. Turn off the radio and all lamps that are not needed. This will avoid sparks and help save both batteries. And it could save your radio!

5. Open the hoods and locate the positive (+) and negative (-) terminal locations of the other vehicle.

Your vehicle has a remote positive (+) 12-volt jump starting terminal and a remote negative (-) jump starting terminal. You should always use these remote terminals instead of the terminals on the battery.

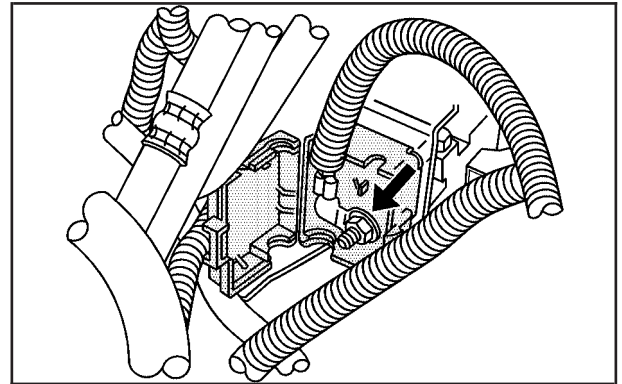

The remote positive (+) terminal is located under a red plastic cover near the center of the engine compartment. See *Engine Compartment Overview* on page 5-4. To access the remote positive (+) terminal, open the red plastic cover.

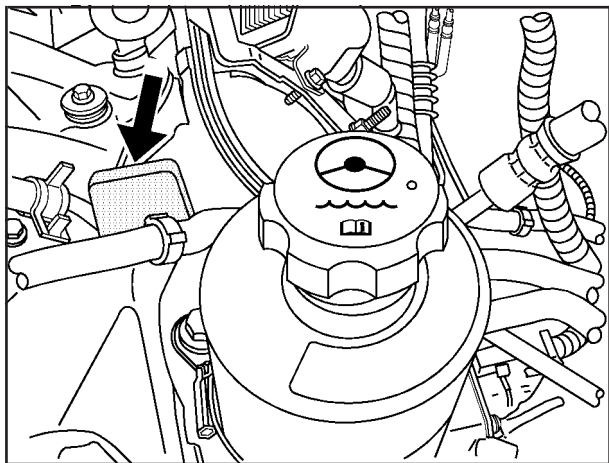

The remote negative (-) terminal is located on the engine accessory drive bracket behind the power steering pump and is marked GND. Do not connect the jumper cables to any part of the power steering pump or hoses.

See *Engine Compartment Overview* on page 5-4 for more information on location of the positive (+) and negative (-) terminals.

⚠ CAUTION:

Using a match near a battery can cause battery gas to explode. People have been hurt doing this, and some have been blinded. Use a flashlight if you need more light.

Be sure the battery has enough water. You do not need to add water to the battery installed in your new vehicle. But if a battery has filler caps, be sure the right amount of fluid is there. If it is low, add water to take care of that first. If you do not, explosive gas could be present. Battery fluid contains acid that can burn you. Do not get it on you. If you accidentally get it in your eyes or on your skin, flush the place with water and get medical help immediately.

⚠ CAUTION:

An electric fan can start up even when the engine is not running and can injure you. Keep hands, clothing and tools away from any underhood electric fan.

⚠ CAUTION:

Fans or other moving engine parts can injure you badly. Keep your hands away from moving parts once the engine is running.

6. Check that the jumper cables do not have loose or missing insulation. If they do, you could get a shock. The vehicles could be damaged too.

Before you connect the cables to the other vehicle, here are some basic things you should know.

Positive (+) will go to positive (+) or to a remote positive terminal (+) if the vehicle has one.

Negative (-) will go to a heavy, unpainted metal engine part or to a remote negative (-) terminal, if the vehicle has one.

Do not connect positive (+) to negative (-) or you will get a short that would damage the battery and maybe other parts too.

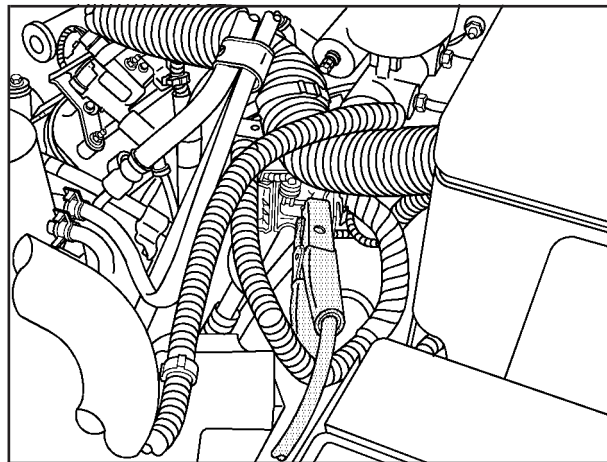

7. Connect the red positive (+) cable to the remote positive (+) terminal of your hybrid vehicle.
8. Do not let the other end touch metal. Connect it to the positive (+) terminal of the good battery. Use a remote positive (+) terminal if the other vehicle has one.

9. Now connect the black negative (-) cable to the negative (-) terminal of the good battery. Use a remote negative (-) terminal if the vehicle has one.

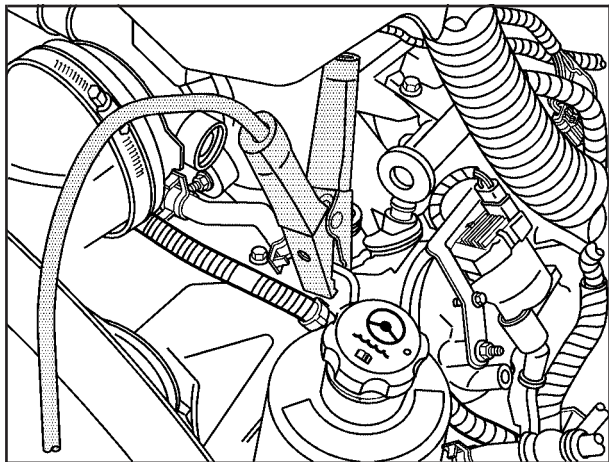

Do not let the other end touch anything until the next step. The other end of the negative (-) cable doesn't go to the dead battery. It goes to your vehicle's remote negative (-) terminal, marked GND. The electrical connection is just as good there, and the chance of sparks getting back to the battery is much less.

10. Now start the vehicle with the good battery.
11. Try to start the hybrid vehicle. Hold the key in the start position for at least three seconds. If the hybrid vehicle still does not start, turn the key to LOCK and wait 5 minutes.
12. After 5 minutes try to start the hybrid vehicle again.
13. Repeat steps 11 and 12 several more times as necessary. If the hybrid vehicle still will not start, your vehicle needs service.

Notice: If the jumper cables are connected or removed in the wrong order, electrical shorting may occur and damage the vehicle. The repairs would not be covered by your warranty. Always connect and remove the jumper cables in the correct order, making sure that the cables do not touch each other or other metal.

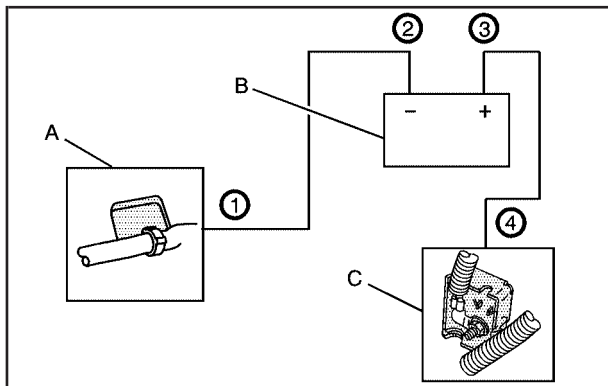

Jumper Cable Removal

- A. Remote Negative (-) Terminal on hybrid vehicle.
- B. Good Battery or Remote Positive (+) and Negative (-) Terminals on other vehicle.
- C. Remote Positive (+) Terminal on hybrid vehicle.

To disconnect the jumper cables from both vehicles do the following:

1. Disconnect the black negative (-) cable from the hybrid vehicle.
2. Disconnect the black negative (-) cable from the vehicle with the good battery.
3. Disconnect the red positive (+) cable from the vehicle with the good battery.
4. Disconnect the red positive (+) cable from the hybrid vehicle.
5. Return the positive (+) remote terminal cover on your hybrid vehicle to its original position.

Electrical System

Battery Disconnect Switch

Notice: Placing items that weigh more than 200 lbs (90 kg) on the battery box may cause damage to the battery box and electrical system. Never place items weighing more than 200 lbs (90 kg) on the battery box.

If you will not be using your vehicle for a period of 30 days or more, you will need to disconnect 42-volt battery power from the vehicle to prevent the batteries from discharging.

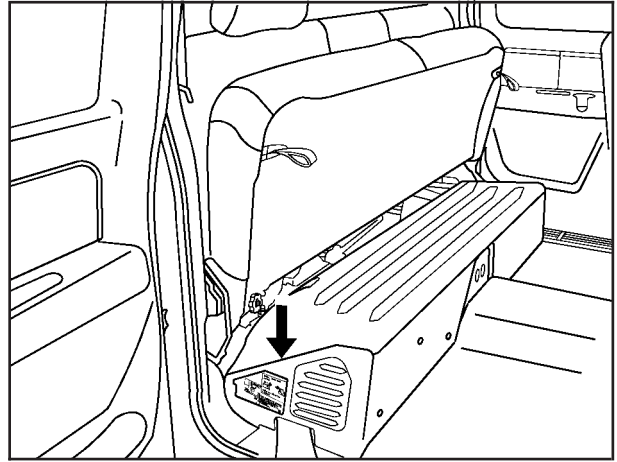

Open the passenger side rear door to access the battery box. The battery disconnect switch is located on the passenger side of the battery box.

To access the battery disconnect switch and disconnect battery power, do the following:

1. Turn the ignition key to LOCK.

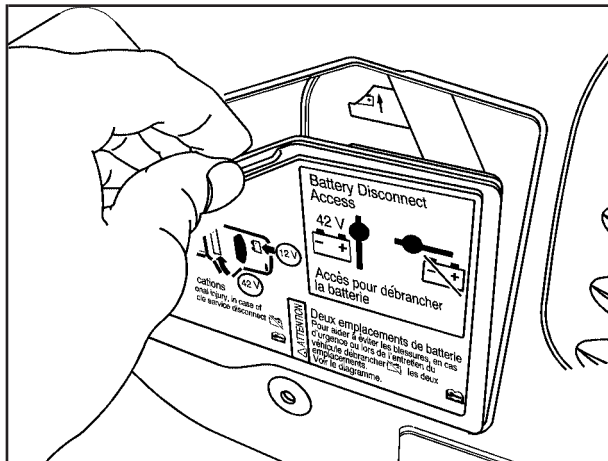

2. Grab the tab at the top of the access door and pull the top of the door out.
3. Pull the access cover up and out from the access opening.

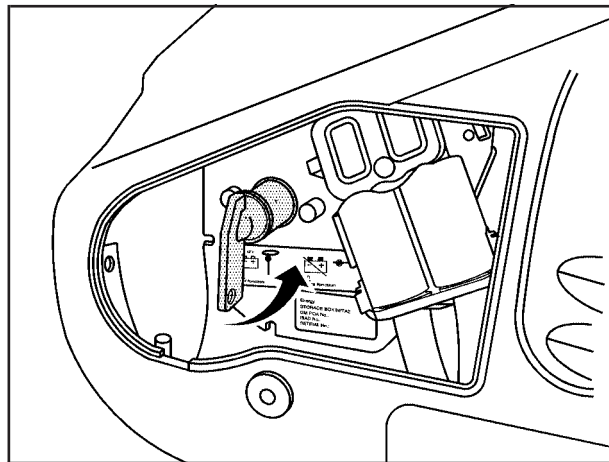

4. Locate the battery disconnect switch.
5. Turn the switch counterclockwise until it stops.

The 42-volt battery power is now disconnected from the vehicle.

This switch can be removed when it is in the off (no power) position.

When you are ready to reconnect battery power to the vehicle, turn the switch clockwise until it stops.

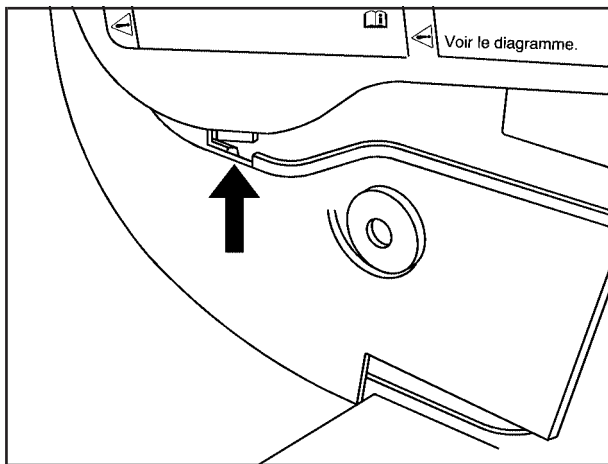

Fuses and Circuit Breakers

The wiring circuits in your vehicle are protected from short circuits by a combination of fuses, circuit breakers and fusible thermal links. This greatly reduces the chance of fires caused by electrical problems.

Be sure you replace a bad fuse with a new one of the identical size and rating.

If you ever have a problem on the road and do not have a spare fuse, you can borrow one that has the same amperage. Just pick some feature of your vehicle that you can get along without — like the radio or cigarette lighter — and use its fuse, if it is the correct amperage. Replace it as soon as you can.

Your vehicle also has a special fuse in the battery box for the 42-volt batteries. If this fuse has failed and needs to be replaced, the vehicle will be disabled and you will need to have your vehicle repaired by your dealer. Do not attempt to self-service this fuse.

6. Reinstall the access door by first placing the tab on the access door into the slot on the lower edge of the battery box access opening.
7. Push the corners of the access door in until they snap into place.

If your 42-volt battery system is disconnected due to an airbag inflation or right-side impact, you must take your vehicle to a qualified service technician to have the 42-volt battery system reconnected. See *What Will You See After an Airbag Inflates?* on page 1-2 for more information.

Hybrid Underhood Fuse Block

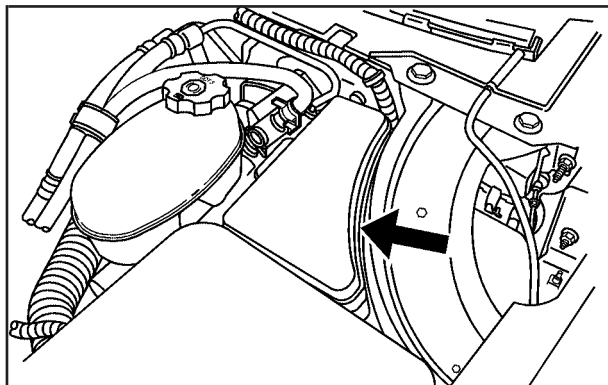

The hybrid underhood fuse block is located in the engine compartment on the driver's side of the vehicle near the main underhood fuse block. Lift the cover for access to the fuse/relay block. See *Engine Compartment Overview on page 5-4* for more information on its location. For more information on the main underhood fuse block see "Underhood Fuse Block" in the Index of your owner manual.

To remove fuses, hold the end of the fuse between your thumb and index finger and pull straight out.

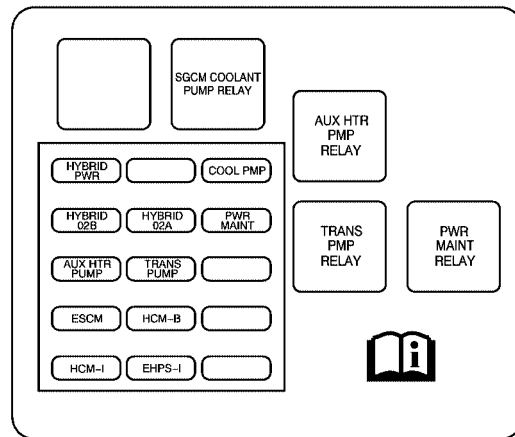

Relays	Usage
SGCM COOLANT PUMP RELAY	SGCM Coolant Fan Pump Relay
AUX HTR PUMP RELAY	Auxiliary Heater Pump
TRANS PUMP RELAY	Transmission Pump
PWR MAINT RELAY	Power Maintain

Fuses	Usage
HYBRID PWR	Hybrid Cooling
COOL PUMP	SGCM Cooling Pump
HYBRID 02B	Hybrid Oxygen Sensors – Bank B
HYBRID 02A	Hybrid Oxygen Sensors – Bank A
PWR MAINT	Power Maintain
AUX HTR PUMP	Auxiliary Heater Pump
TRANS PUMP	Transmission Pump
Empty	Not Used
ESCM	Energy Storage Control Module
HCM-B	Hybrid Control Module – Battery
Empty	Not Used
HCM-I	Hybrid Control Module – Ignition
EHPS-I	Electrohydraulic Power Steering – Ignition
Empty	Not Used

Tires

Changing a Flat Tire

Removing the Jack and Tools

Your hybrid vehicle requires a different procedure to remove the jack and tools from the vehicle. See “Changing a Flat Tire” in the owner manual Index for complete instructions on changing a flat tire.

The equipment is under the passenger’s side second row seat behind the battery box. You must first fold the seat cushion before removing the jack and tools.

Use the following procedure:

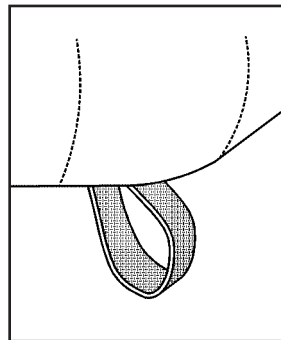

1. Pull up and out on the release strap located under the seat cushion.

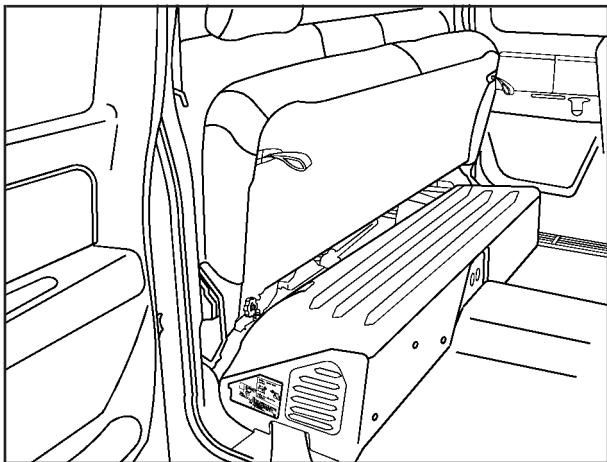

2. Fold the seat cushion upward until it latches with the seatback.
3. Push and pull on the seat cushion to make sure the seat is secure.

4. Turn the wing nut (B) counterclockwise until loosened and flip the black retaining clip back to remove the storage bag and tools (C) from the vehicle.

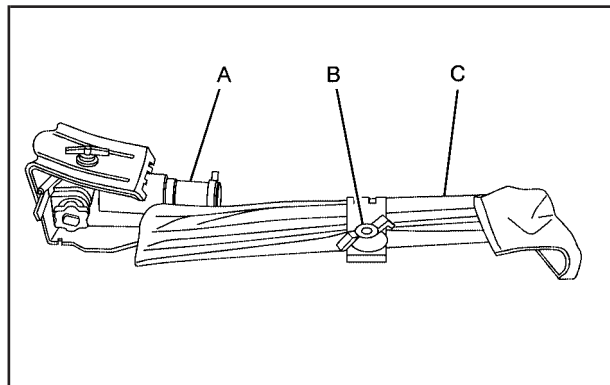

- A. Jack and Wheel Blocks
- B. Wing Nut
- C. Tool Kit

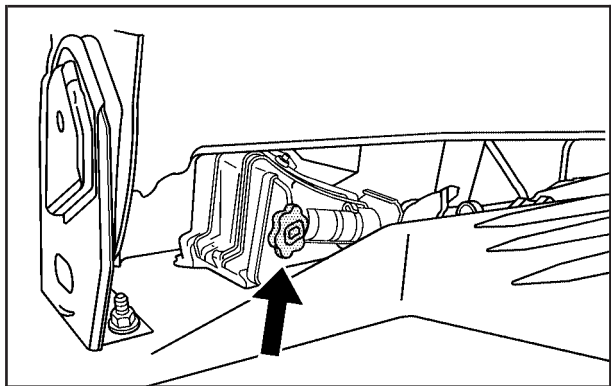

5. Release the jack and wheel blocks (A) from the holder as an assembly by turning the yellow knob on the jack counterclockwise to lower the jack head.

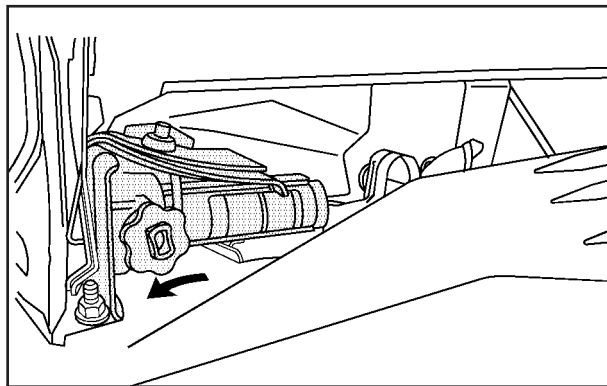

6. Pull the jack back toward the seat bracket.

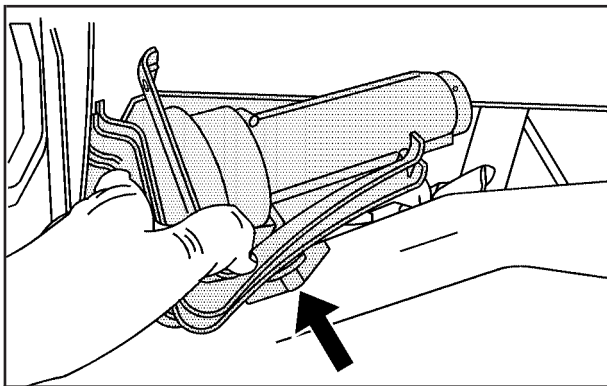

7. Turn the jack upside down so the small wing nut holding the wheel blocks is facing the battery box.

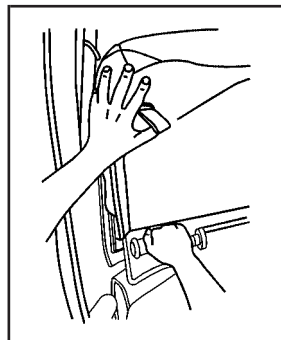

8. Push the seat cushion back while pulling the jack out.

Pulling the jack out this way will reduce the potential of scratching the battery cover.

9. Loosen the wing nut on top of the wheel blocks by turning it counterclockwise to separate the wheel blocks from the jack.

When you are finished, place the tools in the storage bag and reinstall the tools in the vehicle by reversing the removal procedure. Reinstall the wheel blocks to the jack and reinstall the jack back into the vehicle by reversing the removal procedure.

Capacities and Specifications

Auxiliary Power Outlet (APO) Specifications

Maximum Output Power	2.4 kw
Output Voltage	120 VAC +5% –8% measured at the outlets
Current Output (Maximum Continuous)	20 Amps
Output Frequency	60 Hz \pm 0.25 Hz
Total Harmonic Distortion (THD)	\leq 10%
Overload Protection Level	21 A(rms) current limit for 5 seconds
Ground Fault Detection Level	\geq 6ma

Capacities

Application	Capacities	
	English	Metric
Hybrid Cooling System	2.1 quarts	2.0 L
After refill, the level must be rechecked.		

Section 6 Maintenance Schedule

Maintenance Schedule	6-2
Recommended Fluids and Lubricants	6-2
Engine Drive Belt Routing	6-2

Maintenance Schedule

Recommended Fluids and Lubricants

Fluids and lubricants identified below by name, part number, or specification may be obtained from your dealer.

Usage	Fluid/Lubricant
Power Steering System	Electrohydraulic Power Steering Fluid (GM Part No. U.S. 88901975, in Canada 88901976).
Starter Generator Control Module (SGCM) Engine Coolant	50/50 mixture of clean, drinkable water and use only DEX-COOL [®] Coolant. See "Engine Coolant" in the owner manual.

For all other recommended fluids and lubricants, see "Recommended Fluids and Lubricants" in the Index of your owner manual.

Engine Drive Belt Routing

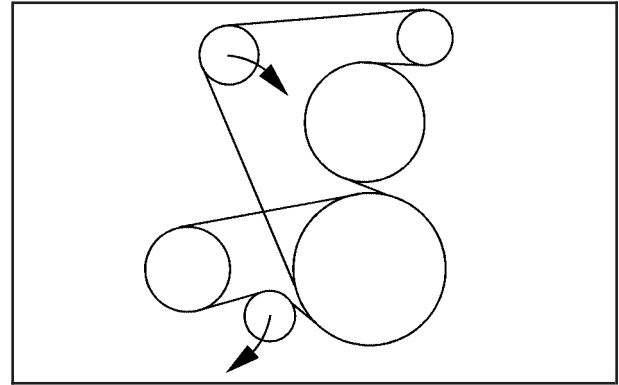

A

Airbag System	
What Will You See After an Airbag Inflates?	1-2
Automatic Transmission, Fluid	5-6
Auxiliary Power Outlet (APO) System	2-2

B

Battery Disconnect Switch	5-20
Braking	
Regenerative	4-2

C

Capacities and Specifications	5-28
Changing a Flat Tire	5-24
Climate Controls	3-2
Cooling System	5-7

D

Driver Information Center (DIC)	
Warnings and Messages	3-2

E

Engine Compartment Overview	5-4
--------------------------------------	-----

F

Fuses and Circuit Breakers	5-22
----------------------------------	------

J

Jump Starting	5-14
---------------------	------

R

Regenerative Braking	4-2
Restraint System Check Replacing Restraint System Parts After a Crash	1-2

S

Service, Doing Your Own Work	5-3
Specifications, Capacities	5-28
Starting Your Vehicle	2-8

T

Tires Changing a Flat	5-24
Towing Trailer	4-2
Transmission, Automatic Fluid	5-6